



MtM+ Technology

# M907

---

## Bluetooth 4.2 Low Energy/Zigbee/RF4CE/Thread SiP Module

with MCU and integrated antenna

---

Preliminary DATASHEET  
19<sup>th</sup> April, 2018

# Table of Contents

1	Product Brief.....	1
2	Features and Applications .....	2
3	Block Diagram.....	3
4	Technical Specifications.....	4
4.1	Absolute Maximum Ratings .....	4
4.2	Operation Condition .....	4
4.3	Wireless Specifications .....	4
4.4	Radio Specifications – Bluetooth 4.2 Low Energy.....	4
4.5	Built-In Antenna Performance .....	5
4.6	Power Consumption .....	5
5	Dimensions .....	6
6	Pin Assignments.....	7
7	Recommended Footprint .....	8
8	Reference Design Circuit .....	9
9	Recommended Reflow Profile.....	10
10	SiP Module Preparation.....	11
10.1	Handling .....	11
10.2	SMT Preparation .....	11
11	Package Information .....	12
12	Document History.....	13

# 1 Product Brief

The SiP module is a small size module with antenna inside. It's compatible with standards and industrial alliance specifications including Bluetooth Smart (BLE 4.0 and BLE 4.2), BLE Mesh, 6LoWPAN, Thread, Zigbee, RF4CE, HomeKit and 2.4GHz proprietary standard. It allows easy connectivity with Bluetooth Smart Ready mobile phones, tablets, laptops, which supports BLE slave and master mode operation, including broadcast, encryption, connection updates, and channel map updates. It is completely RoHS-compliant and 100% lead (Pb)-free

For the software and driver development, we provide extensive technical document and reference software code for the system integration. Hardware evaluation kit and development utilities are ready to applied.

## KEY FEATURES

- Bluetooth 4.2 Low Energy Compliant
- Embedded 32 bits high performance MCU with clock up to 48MHz
- 512 kB programmable flash
- 32 kB SRAM
- Built-in antenna
- Module size: 12 x 12 mm

## 2 Features and Applications

### Feature List

- Multi-protocol with Bluetooth low energy / ANT / 2.4GHz RF
- Support Zigbee, RF4CE, Thread and Homekit standards
- Embedded 32-bit high performance MCU with clock up to 48MHz
- Program memory: Internal 512KB Flash
- Data memory: 32KB on-chip SRAM
- 12MHz and 32KHz/32MHz embedded RC oscillator
- A rich set of I/Os:
  - Up to 14 GPIOs
  - DMIC (Digital Mic)
  - AMIC (Analog Mic)
  - Mono-channel audio output
  - SPI
  - I<sup>2</sup>C
  - UART with hardware flow control
  - USB
  - Debug Interface
- Up to 6 channels of PWM, 2-channel IR
- Sensor:
  - 14bit ADC with PGA
  - Temperature sensor
- One quadrature decoder
- Embedded hardware AES
- Operating temperature: -40°C ~ +85°C industrial temperature range
- Antenna on Package (AoP)
- LGA-36 package, 12 x 12 mm

### Applications

- IoT:
  - Smart home
  - Sensor networks
  - Building automation
  - Industrial
  - Retail
  - Smart Lighting
- Beacons

### 3 Block Diagram

There is fully integration module with TLSR8269F512, 12MHz low power crystal. Especially, there is a high-performance PCB antenna.

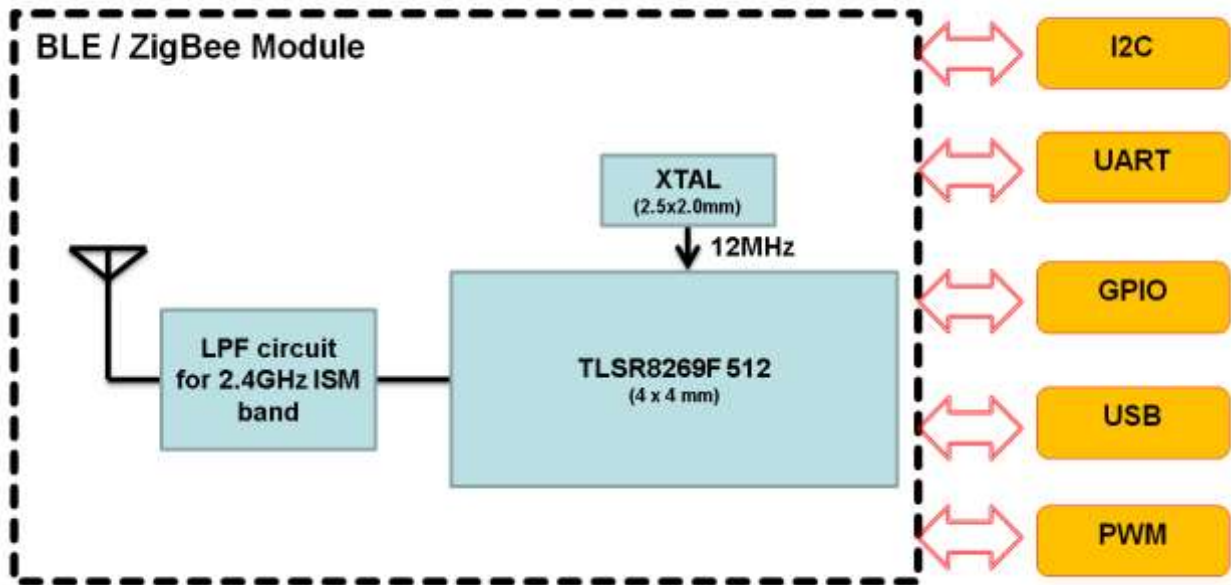

## 4 Technical Specifications

Operation and storage condition

### 4.1 Absolute Maximum Ratings

Item	Description		Value	Unit
<b>Ratings Over Operating Free-Air Temperature Range</b>				
1	Supply voltage	All supply pins must have the same voltage	-0.3 ~ 3.9	V
2	Voltage on any pin		-0.3 ~ 3.9	V
3	Storage temperature range		-40 ~ 125	°C
4	Bluetooth RF output (Typ.)		4	dBm

### 4.2 Operation Condition

Operating Condition	Min	Typical	Max	Unit
VCC	1.7	3.3	3.6	V
Operation ambient temperature range	-40	--	85	°C

### 4.3 Wireless Specifications

The M907 module is compliant with the following features and standards:

Features	Description
Bluetooth Standards	Bluetooth core v4.2 Low Energy
Antenna Port	Built-in Antenna
Frequency Band	2.402 – 2.480 GHz

### 4.4 Radio Specifications – Bluetooth 4.2 Low Energy

Features	Description
Features	Bluetooth core v4.2 Low Energy
Frequency Band	2.402 – 2.480GHz
Number of Selectable Sub Channels	40 Channels
Modulation	GFSK
Support Rates	< 2Mbps
Maximum Receive Level	-10dBm (with PER <30.8%)

## 4.5 Built-In Antenna Performance

Item	Freq. Band	Gain	Return Loss	VSWR
Spec	2.4 to 2.5GHz	>5dBi	<6dB	3 max
Item	Impedance	Polarization	Directivity	Efficiency
Spec	50 ohm	Linear	Omni-directional	>30%

## 4.6 Power Consumption

Item	Typical	Units
Tx Mode 3.3V	40	mA
Rx Mode 3.3V	29	mA
Deep Sleep Mode (MCU ON)	1.9	uA
Suspend Mode (MCU ON, SRAM ON to keep data)	10.3	uA





## 6 Pin Assignments

Pin Number	Pin Name	Pin Function	Description
1	DM/ANA_E<2>	Digital I/O	USB dataMinus/GPIO/ANA_E<2>
2	DP/ANA_E<3>	Digital I/O	USB data Positive/GPIO/ANA_E<3>
3	DMIC_DI/PWM0/ANA_A<0>	Digital I/O	DMIC data input/PWM0/GPIO/ANA_A<0>
4	RESETB	RESET	Power on reset, active low
5	DI/PWM1/ANA_A<3>	Digital I/O	SPI data input/PWM1 output/GPIO/ANA_A<3>/I2C_SDA (I2C serial data)
6	CK/PWM1_N/ANA_A<4>	Digital I/O	SPI clock/PWM1 inverting output/GPIO/ANA_A<4>/I2C_SCK (I2C serial clock)
7	PWM1/SDM_P/ANA_E<1>	Digital I/O	PWM1 output/GPIO /SDM Negative output /ANA_E<1>
8	PWM0/SDM_N/ANA_E<0>	Digital I/O	PWM0 output/GPIO /SDM Positive output/ANA_E<0>
9	GP5/ANA_D<3>	Digital I/O	GPIO5/ANA_D<3>
10	VBAT	Power	3V3
11	GND	Power	Ground (0V)
12	GND	Power	Ground (0V)
13	UART_RX/SWM/ANA_A<7>	Digital I/O	UART_RX/Single Wire Master/GPIO/ANA_A<7>
14	PWM2/SWS/ANA_B<0>	Digital I/O	PWM2 output/Single wire slave/GPIO/ANA_B<0>
15	PWM2_N/ANA_B<1>	Digital I/O	PWM2 inverting output /GPIO/ANA_B<1>
16	CN/PWM4/ANA_B<4>	Digital I/O	SPI chip select (Active low)/PWM4 output/GPIO/ ANA_B<4>
17	DO/PWM4_N/ANA_B<5>	Digital I/O	SPI data output/PWM4 inverting output/GPIO/ ANA_B<5>
18	DI/PWM5/ANA_B<6>	Digital I/O	SPI data input/PWM5 output/ GPIO/ANA_B<6>/I2C_SDA (I2C serial data)
19	CK/PWM5_N/ANA_B<7>	Digital I/O	SPI clock/ PWM5 inverting output/ GPIO/ANA_B<7>/I2C_SCK (I2C serial clock)
20	UART_TX/PWM2/ANA_C<2>	Digital I/O	UART_TX/PWM2 output/GPIO/ANA_C<2>/ (optional) 32KHz crystal output
21	UART_RX/PWM3/ANA_C<3>	Digital I/O	UART_RX/PWM3 output/GPIO/ANA_C<3>/ (optional) 32KHz crystal input
22	UART_RTS/PWM4/ANA_C<4>	Digital I/O	UAR_RTS/PWM4 output/ GPIO /ANA_C<4>
23	UART_CTS/PWM5/ANA_C<5>	Digital I/O	RT_CTS/PWM5 output/ GPIO /ANA_C<5>
24	GP4/ANA_D<2>	Digital I/O	GPIO4/ANA_D<2>
25~30	GND	Power	Ground (0V)
31	RF OUT		
32	ANT IN		
33~36	GND	Power	Ground (0V)

# 7 Recommended Footprint

Suggest on PCB: SMD (1:1)

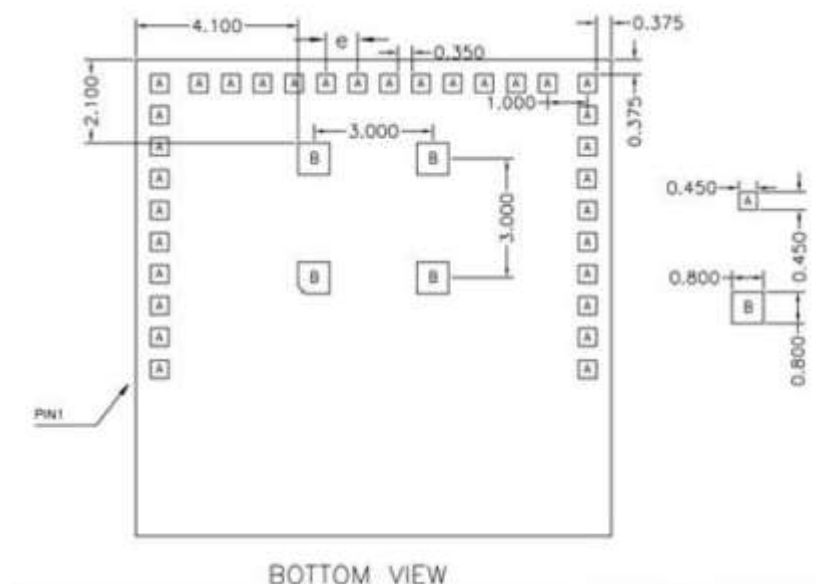

e = BSC 0.80

# 8 Reference Design Circuit

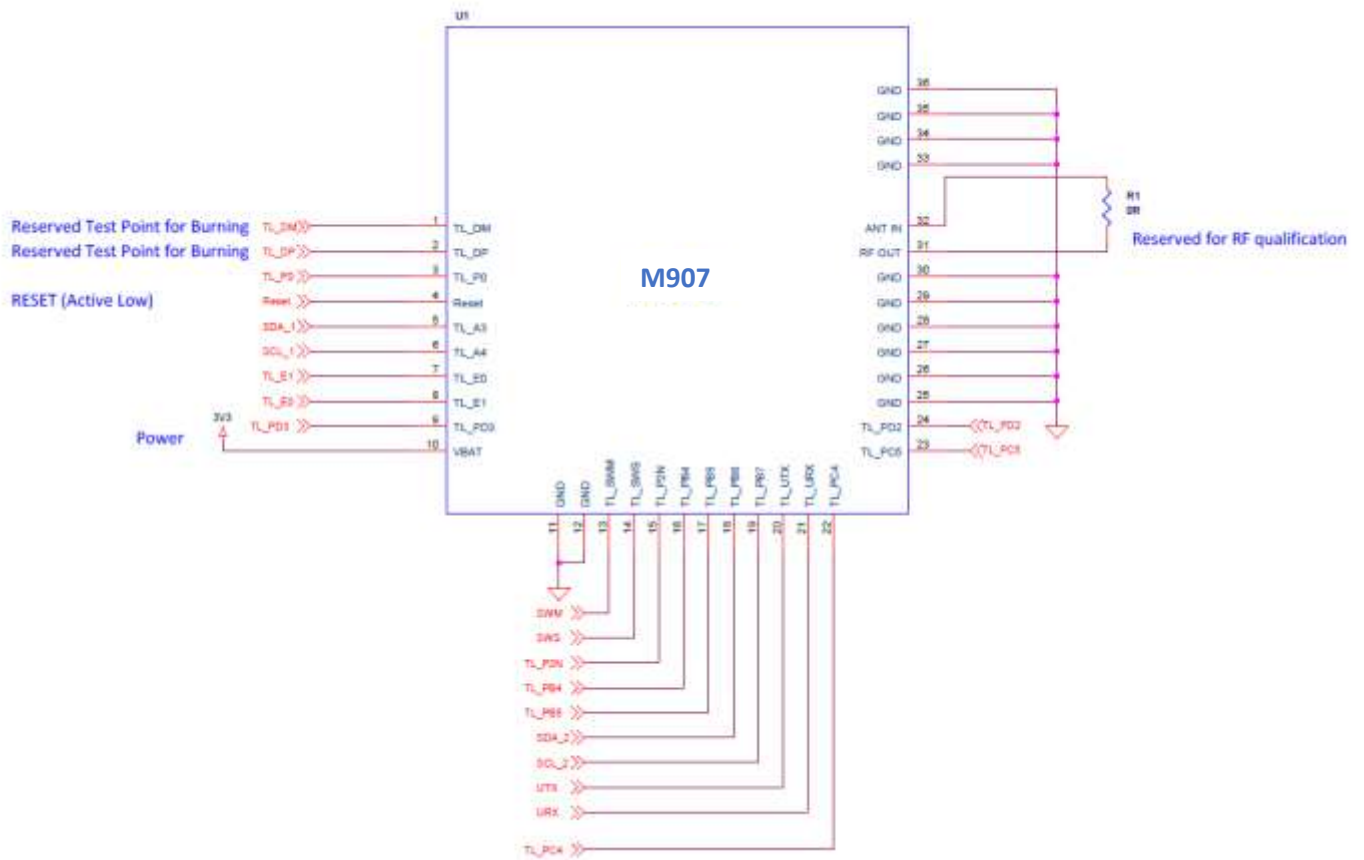

## 9 Recommended Reflow Profile

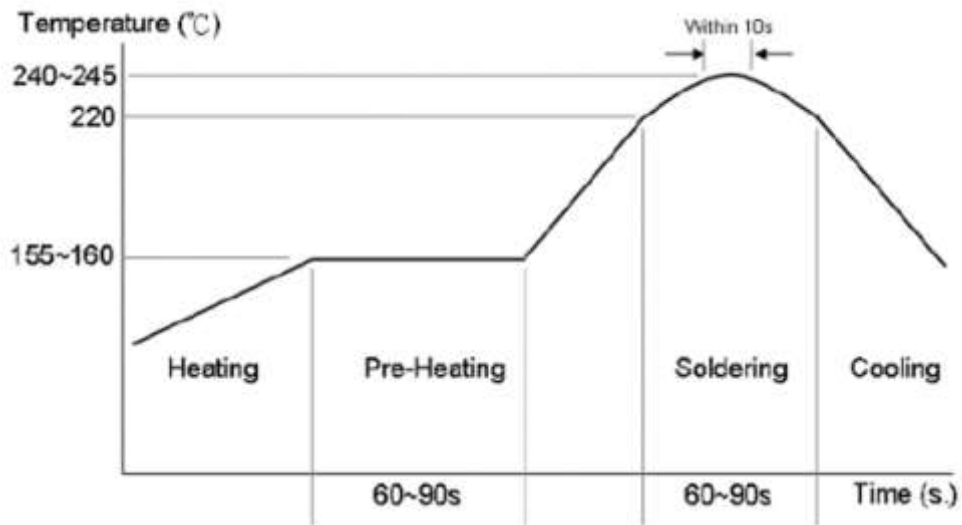

### Profile Condition

- Suitable for lead-free solder
- Between 155 ~ 160°C: 60 ~ 90 sec.
- Above 220°C: 60 ~ 90 sec.
- Peak Temperature: 240 ~ 245°C (<10 sec.)

# 10 SiP Module Preparation

## 10.1 Handling

Handling the module must wear the anti-static wrist strap to avoid ESD damage. After each module is aligned and tested, it should be transport and storage with anti-static tray and packing. This protective package must be remained in suitable environment until the module is assembled and soldered onto the main board.

## 10.2 SMT Preparation

1. Calculated shelf life in sealed bag: 6 months at  $<40^{\circ}\text{C}$  and  $<90\%$  relative humidity (RH).
2. Peak package body temperature:  $250^{\circ}\text{C}$ .
3. After bag was opened, devices that will be subjected to reflow solder or other high temperature process must.
  - a. Mounted within: 72 hours of factory conditions  $<30^{\circ}\text{C} / 60\%$  RH.
  - b. Stored at  $\leq 10\%$  RH with N2 flow box.
4. Devices require baking, before mounting, if:
  - a. Package bag does not keep in vacuumed while first time open.
  - b. Humidity Indicator Card is  $>10\%$  when read at  $23\pm 5^{\circ}\text{C}$ .
  - c. Expose at 3A condition over 8 hours or Expose at 3B condition over 24 hours.
5. If baking is required, devices may be baked for 12 hours at  $125\pm 5^{\circ}\text{C}$ .

# 11 Package Information

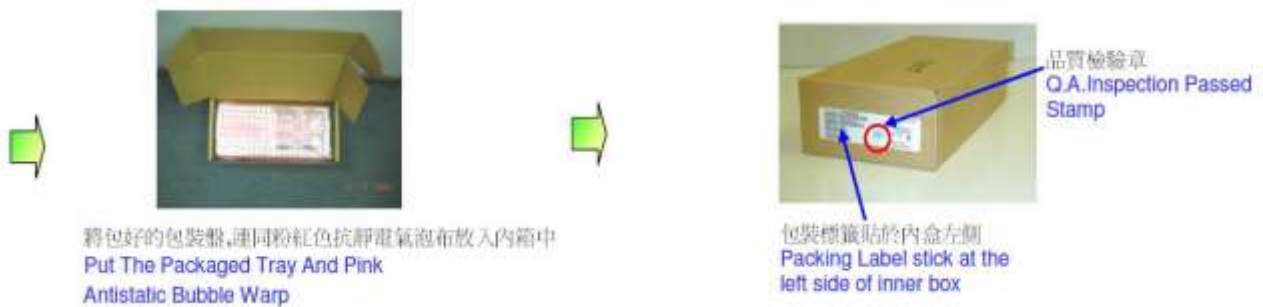

## 12 Document History

Date	Modifications	Version
Mar. 08, 2017	Preliminary Version	1.0
Dec. 11, 2017	Fixed description details	1.1
Feb. 26, 2018	Add power consumption	1.2
Apr. 10, 2018	Update the content of "2 Features and Applications"	1.3
Apr. 19, 2018	Update content of "5 Dimension", "6 Pin Assignments", "7 Recommended Footprint" and "8 Reference Design Circuit"	1.4

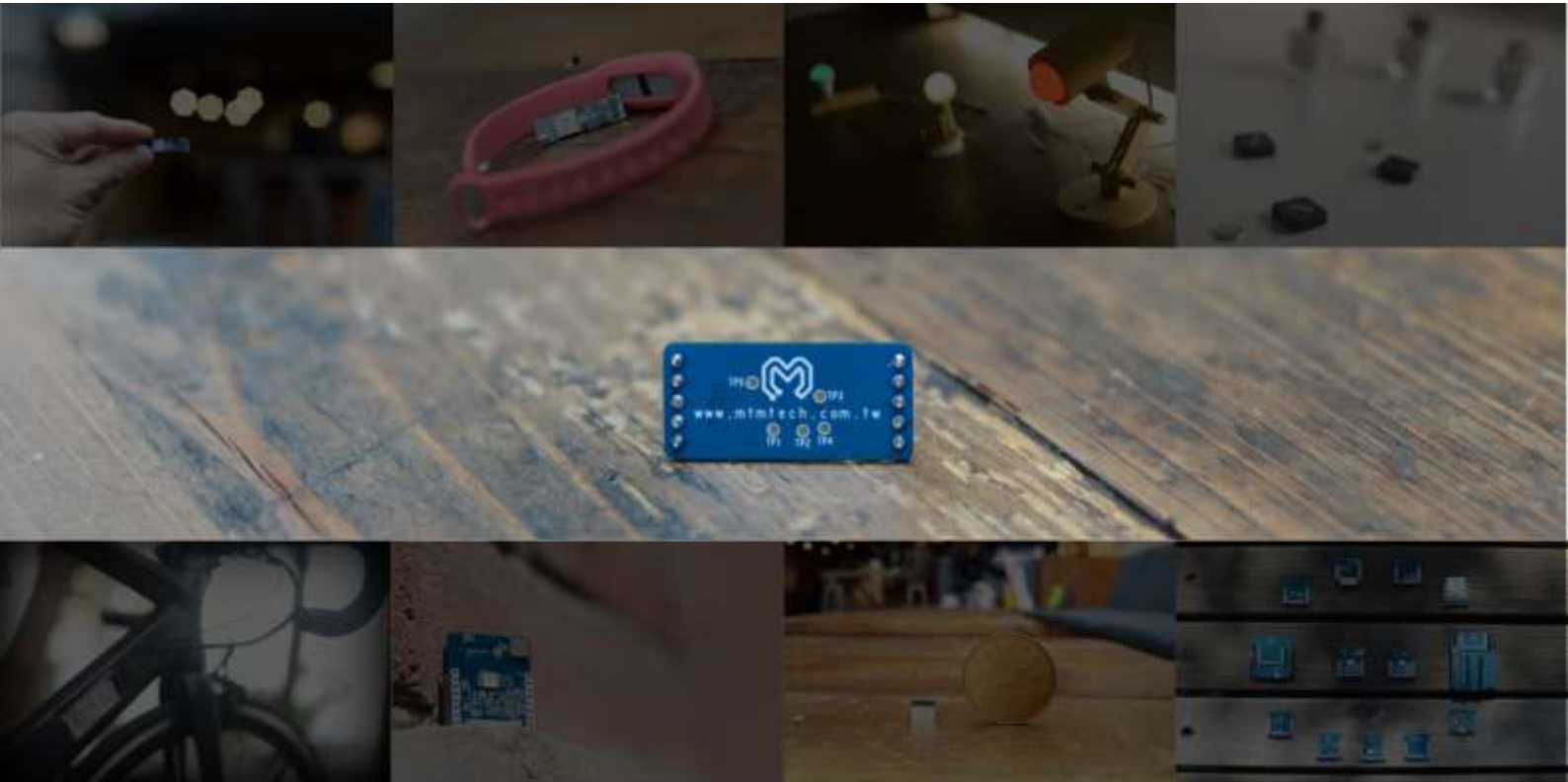

## MtM+ Technology Corporation

7F, 178 MinQuan East Road Section 3,  
Songshan District, Taipei,  
Taiwan (R.O.C.)

+886-2-7736-7386



<http://www.mtmtech.com.tw>



<http://blog.mtmtech.com.tw>



<https://www.facebook.com/MtMTechnologyCorporation>



<http://www.instagram.com/mtmtech>

© 2018 MtM+ Technology Corporation

**DISCLAIMER:** The information in this document is provided in connection with MtM+ Technology products. No license, express or implied, by estoppel or otherwise, to any intellectual property rights granted by this document or in connection with the sale of MtM+ Technology products. MTM TECHNOLOGY ASSUMES NO LIABILITY WHATSOEVER AND DISCLAIMS ANY EXPRESS, IMPLIED OR STATUTORY WARRANTY RELATING TO ITS PRODUCTS INCLUDING, BUT NOT LIMITED TO, THE IMPLIED WARRANTY OF MERCHANTABILITY, FITNESS FOR A PARTICULAR PURPOSE, OR NON-INFRINGEMENT. IN NO EVENT SHALL MTM TECHNOLOGY BE LIABLE FOR ANY DIRECT, INDIRECT, CONSEQUENTIAL, PUNITIVE, SPECIAL OR INCIDENTAL DAMAGES (INCLUDING, WITHOUT LIMITATION, DAMAGES FOR LOSS AND PROFITS, BUSINESS INTERRUPTION, OR LOSS OF INFORMATION) ARISING OUT OF THE USE OR INABILITY TO USE THIS DOCUMENT, EVEN IF MTM TECHNOLOGY HAS BEEN ADVISED OF THE POSSIBILITY OF SUCH DAMAGES. MtM+ Technology makes no representations or warranties with respect to the accuracy or completeness of the contents of this document and reserves the right to make changes to specifications and products descriptions at any time without notice. MtM+ Technology does not make any commitment to update the information contained herein. MtM+ Technology products are not intended, authorized, or warranted for use as components in applications intended to support or sustain life.

**SAFETY-CRITICAL, MILITARY, AND AUTOMOTIVE APPLICATIONS DISCLAIMER:** MtM+ Technology products are not designed for and will not be used in connection with any applications where the failure of such products would reasonably be expected to result in significant personal injury or death ("Safety -Critical Applications") without an MtM+ officer's specific written consent. Safety-Critical Applications include, without limitation, life support devices and systems, equipment or systems for the operation of nuclear facilities and weapons systems. MtM+ Technology products are not designed nor intended for use in military or aerospace applications or environments unless specifically designated by MtM+ Technology as military-grade.