



SPORTON LAB.

Certificate No: EH300919

CERTIFICATE OF COMPLIANCE

● **EQUIPMENT : Wireless Pedometer/Tracker**

MODEL NO. : M903

APPLICANT : ASE Group

4F, No 133, Sec 4, Mingsheng E Rd, Songshan Dist, Taipei, Taiwan



I HEREBY

CERTIFY THAT:

The product sample completely tested on **Oct. 24, 2013**. We, SPORTON, would like to declare that the tested sample has been evaluated in accordance with the procedures given in **EN 301 489-1 V1.9.2 (2011-09) and EN 301 489-17 V2.2.1 (2012-09)** and shown compliance with the applicable technical standards. The equipment under R&TTE Directive 1999/5/EC of article 3.1(b) harmonized essential for the EMC requirements.

Wayne Hsu
Assistant Manager

CE Test Report

Equipment : Wireless Pedometer/Tracker
Brand Name : ASE Group
Model No. : M903
Standard : EN 301 489-1 V1.9.2 (2011-09)
EN 301 489-17 V2.2.1 (2012-09)
Applicant : ASE Group
Manufacturer : ASE Group
4F,No 133, Sec 4, Mingsheng E Rd,
Songshan Dist, Taipei, Taiwan

The product sample received on Oct. 09, 2013 and completely tested on Oct. 24, 2013. We, SPORTON, would like to declare that the tested sample has been evaluated in accordance with the procedures given in EN 301 489-1 V1.9.2 (2011-09) and shown compliance with the applicable technical standards. The equipment under R&TTE Directive 1999/5/EC of article 3.1b harmonized essential for the EMC requirements.

The test results in this report apply exclusively to the tested model / sample. Without written approval of SPORTON INTERNATIONAL INC., the test report shall not be reproduced except in full.

Reviewed by:

Wayne Hsu / Assistant Manager





Table of Contents

1 SUMMARY OF TEST RESULT	1
2 GENERAL INFORMATION.....	3
2.1 Product Details.....	3
2.2 Test Manner.....	3
2.3 Table for Testing Locations.....	3
2.4 Table for Supporting Units.....	3
2.5 EUT Operation during Test.....	3
2.6 Test Configurations.....	4
3 EMISSION TESTS RESULT	5
3.1 Test of Conducted Powerline and Telecommunication Line.....	5
3.2 Telecommunication Line Conducted Emissions Measurement.....	6
3.3 Radiated Emissions Measurement.....	7
3.4 Harmonic Current Emissions Measurement.....	16
3.5 Voltage Fluctuation and Flicker Measurement.....	18
4 IMMUNITY TESTS RESULT	19
4.1 Electrostatic Discharge Immunity Measurement (ESD).....	19
4.2 Radio Frequency Electromagnetic Field Immunity Measurement (RS).....	22
4.3 Electrical Fast Transient/Burst Immunity Measurement (EFT).....	25
4.4 Surge Immunity Measurement (Surge).....	27
4.5 Conducted Disturbances Induced by RF Field Immunity Measurement (CS).....	29
4.6 Voltage Dips and Voltage Interruption Immunity Measurement (DIP).....	31
5 UNCERTAINTY	33
6 LIST OF MEASURING EQUIPMENTS.....	36
7 TEST LOCATION.....	38
APPENDIX A. TEST PHOTOS	
APPENDIX B. PHOTOGRAPHS OF EUT	



1 SUMMARY OF TEST RESULT

EN 301 489-1 V1.9.2 (2011-09) Emission Tests and Conformance Test Specifications				
Report Clause	Ref. Std. Clause	Test Standard	Description of Test	Result
3.1	8.4	EN 55022:2006/A1:2007	AC Power Conducted Emissions	NA
3.1	8.7	EN 55022:2006/A1:2007	Telecom Port Conducted Emissions	NA
3.3	8.2	EN 55022:2006/A1:2007	Radiated Emissions	Complied
3.4	8.5	EN 61000-3-2:2006/A1:2009 EN 61000-3-2:2006/A2:2009	Harmonic Current Emissions	NA
3.5	8.6	EN 61000-3-3:2008	Voltage Fluctuations and Flicker	NA

Note 1: equipment w/o AC main port and telecom port.

Remark: The "NA" is Not Applicable.

EN 301 489-1 V1.9.2 (2011-09) Immunity Tests and Conformance Test Specifications				
Report Clause	Ref. Std. Clause	Test Standard	Description of Test	Result
4.1	9.3	EN 61000-4-2:2009	ESD (Enclosure)	Complied
4.2	9.2	EN 61000-4-3:2006/A1:2008/A2:2010	RS (Enclosure)	Complied
4.3	9.4	EN 61000-4-4:2004/A1:2010	EFT (AC Power Port)	NA
4.3	9.4	EN 61000-4-4:2004/A1:2010	EFT (Signal and telecommunication ports)	NA
4.4	9.8	EN 61000-4-5:2006	Surge (AC Power Port)	NA
4.4	9.8	EN 61000-4-5:2006	Surge (Signal and telecommunication ports)	NA
4.5	9.5	EN 61000-4-6:2009	CS (AC Power Port)	NA
4.5	9.5	EN 61000-4-6:2009	CS (Signal and telecommunication ports)	NA
4.6	9.7	EN 61000-4-11:2004	DIP (AC Power Port)	NA

Note 1: equipment w/o AC main port and telecom port.

Remark: The "NA" is Not Applicable.



Criteria	During test	After test
A	Shall operate as intended. May show degradation of performance (see note 1). Shall be no loss of function. Shall be no unintentional transmissions.	Shall operate as intended. Shall be no degradation of performance (see note 2). Shall be no loss of function. Shall be no loss of stored data or user programmable functions.
B	May show loss of function (one or more). May show degradation of performance (see note 1). No unintentional transmissions.	Functions shall be self-recoverable. Shall operate as intended after recovering. Shall be no degradation of performance (see note 2). Shall be no loss of stored data or user programmable functions.
C	May be loss of function (one or more).	Functions shall be recoverable by the operator. Shall operate as intended after recovering. Shall be no degradation of performance (see note 2).
NOTE 1:	Degradation of performance during the test is understood as a degradation to a level not below a minimum performance level specified by the manufacturer for the use of the apparatus as intended. In some cases the specified minimum performance level may be replaced by a permissible degradation of performance. If the minimum performance level or the permissible performance degradation is not specified by the manufacturer then either of these may be derived from the product description and documentation (including leaflets and advertising) and what the user may reasonably expect from the apparatus if used as intended.	
NOTE 2:	No degradation of performance after the test is understood as no degradation below a minimum performance level specified by the manufacturer for the use of the apparatus as intended. In some cases the specified minimum performance level may be replaced by a permissible degradation of performance. After the test no change of actual operating data or user retrievable data is allowed. If the minimum performance level or the permissible performance degradation is not specified by the manufacturer then either of these may be derived from the product description and documentation (including leaflets and advertising) and what the user may reasonably expect from the apparatus if used as intended.	

2 GENERAL INFORMATION

2.1 Product Details

The equipment is Wireless Pedometer/Tracker. There are two samples of EUT. The only difference is the outward appearances. For more detailed features description, please refer to the manufacturer's specifications or user's manual.

2.2 Test Manner

Test Items	Description of test modes
Radiated Emissions	Mode 1. Bluetooth Mode
Harmonic and Flicker Emissions	Mode 1. Bluetooth Mode
EMS	Mode 1. Bluetooth Mode

Reminder:

1. Frequency range investigated: Radiation 30 MHz to 6,000 MHz.
2. Frequency range investigated immunity test: RS 80 MHz to 2,700 MHz.

2.3 Table for Testing Locations

Test Site No.	Site Category	Location	Test Site No.	Site Category	Location
10CH01HY (Blew 1GHz)	SAC	Hwa Ya	ES01-HY	ESD	Hwa Ya
03CH04-HY (Above 1GHz)	SAC	Hwa Ya	RS01-HY	RS	Hwa Ya

Open Area Test Site (OATS); Semi Anechoic Chamber (SAC).

2.4 Table for Supporting Units

Support Unit	Brand	Model
iPad Mini (Remote Workstation)	Apple	A1455

2.5 EUT Operation during Test

The iPad mini at remote workstation executed "PedometerAPP" under IOS to maintain the connection by EUT.

2.6 Test Configurations

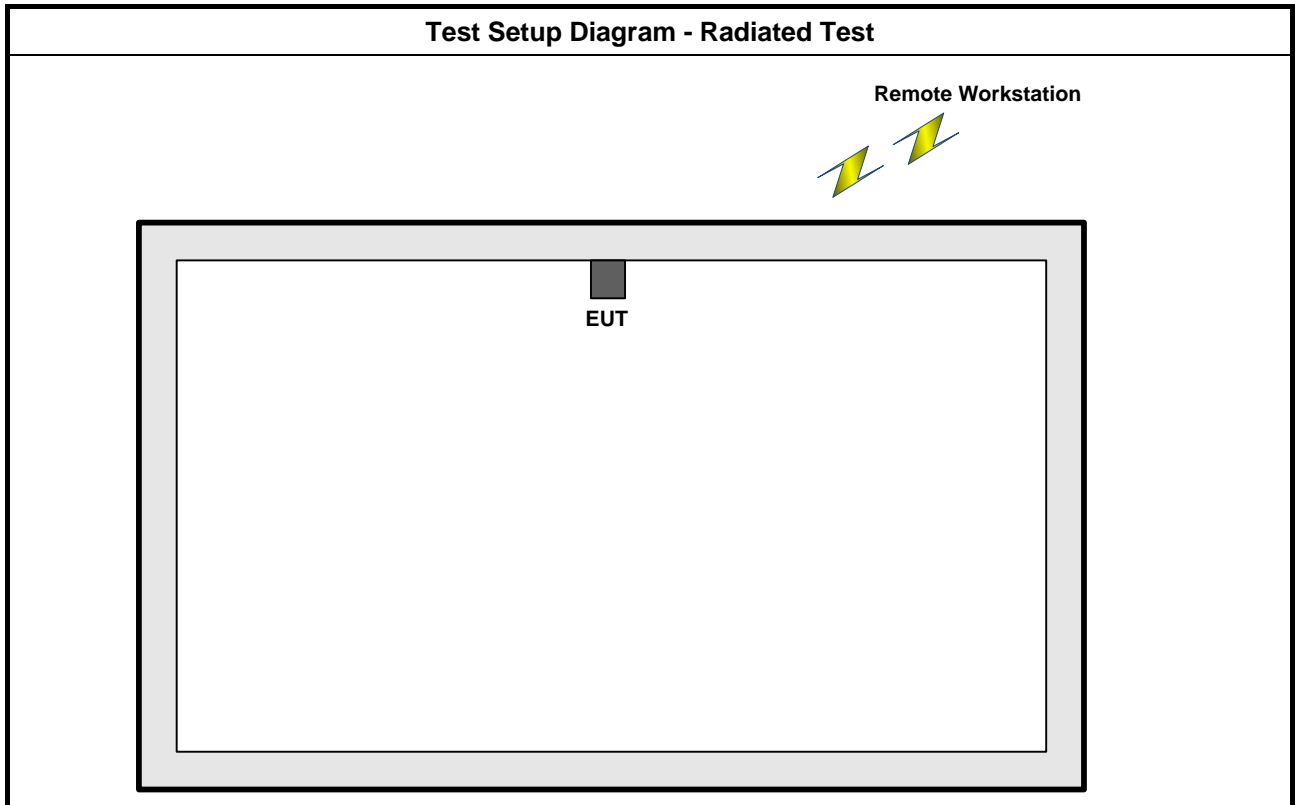

3 EMISSION TESTS RESULT

3.1 Test of Conducted Powerline and Telecommunication Line

3.1.1 Limit

For this product which is designed to be connected to the AC power line, the radio frequency voltage that is conducted back onto the AC power line on any frequency or frequencies within the band 150 kHz to 30 MHz shall not exceed below limits table.

Frequency (MHz)	QP Limit (dBuV)	AV Limit (dBuV)
0.15~0.5	66~56	56~46
0.5~5	56	46
5~30	60	50

For a device, which is designed to be connected to the telecommunication line, the radio frequency voltage that is conducted back onto the telecommunication line on any frequency or frequencies within the band 150 kHz to 30 MHz shall not exceed below limits table.

Me For a device, which is designed to be connected to the telecommunication line, the radio frequency voltage that is conducted back onto the telecommunication line on any frequency or frequencies within the band 150 kHz to 30 MHz shall not exceed below limits table.

Frequency (MHz)	Voltage		Current	
	QP Limit (dBuV)	AV Limit (dBuV)	QP Limit (dBuA)	AV Limit (dBuA)
0.15~0.5	84~74	74~64	40~30	30~20
0.5~30	74	64	30	20

3.1.2 Measuring Instruments and Setting

See list of measuring instruments of this test report.

Receiver Parameters	Setting
Attenuation	10 dB
Start Frequency	0.15 MHz
Stop Frequency	30 MHz
IF Bandwidth	9 kHz

3.1.3 Test Procedures

1. The EUT was warmed up for 15 minutes before testing started.
2. The EUT was placed on a desk 0.8 meters height from the metal ground plane and 0.4 meter from the conducting wall of the shielding room and it was kept at least 0.8 meters from any other grounded conducting surface.
3. Connect EUT to the power mains through a line impedance stabilization network (LISN).
4. Connect telecommunication port to ISN (Impedance Stabilization Network).
5. All the support units are connect to the other LISN.
6. The LISN provides 50 ohm coupling impedance for the measuring instrument.
7. The CISPR states that a 50 ohm, 50 microhenry LISN should be used.
8. Both sides of AC line were checked for maximum conducted interference.
9. The frequency range from 150 kHz to 30 MHz was searched.
10. Set the test-receiver system to Peak Detect Function and Specified Bandwidth with Maximum Hold Mode.

3.1.4 Typical Test Setup Layout of Conducted Powerline and Telecommunication Ports

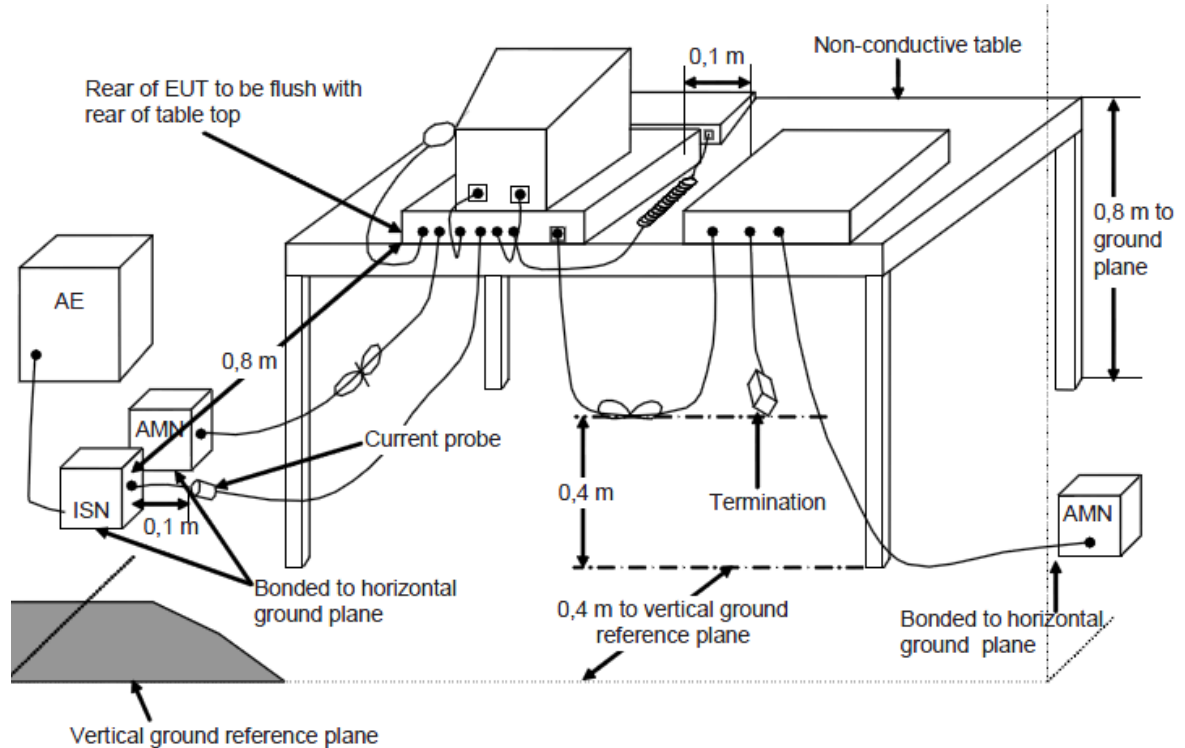

3.1.5 Results of AC Power Line Conducted Emissions Measurement

The EUT is battery powered and the AC power line Conducted Emission is not required.

3.2 Telecommunication Line Conducted Emissions Measurement

The test item needn't to be performed due to the EUT without telecommunication port.

3.3 Radiated Emissions Measurement

3.3.1 Limit

Radiated emissions below 1 GHz were measured with a bandwidth of 120 kHz for 30 MHz to 1,000 MHz and bandwidth of 1 MHz for above 1 GHz, the measurement shall be made up to 5 times the highest frequency or 6GHz (Based on the highest operating frequency of EUT), whichever is lower. The quasi-peak measuring receiver shall be in accordance with clause 2 of EN55016-1. Receivers with peak detectors shall be in accordance with clause 3 of EN55016-1, and shall have a 6 dB bandwidth in accordance with clause 2 of EN55016-1 and above 1GHz measurement method shall be as specified in 7.3 of EN55016-2-3.

< Limit: Below 1GHz >

Frequency of Emission (MHz)	Field Strength QP Limit (dBuV/m) at 10m
30 ~ 230	30
230 ~ 1000	37

< Limit: Above 1GHz >

Frequency of Emission (GHz)	Field Strength Limit (dBuV/m) at 3m	
	Average	Peak
1 ~ 3	50	70
3 ~ 6	54	74

3.3.2 Measuring Instruments and Setting

See list of measuring instruments of this test report.

Receiver Parameter	Setting
Attenuation	Auto
Start ~ Stop Frequency	30MHz~1000MHz / RBW 120kHz for QP
Start ~ Stop Frequency	1GHz~6GHz / RBW 1MHz for Peak, Average

3.3.3 Test Procedures

< Below 1GHz >

- a. The EUT was placed on a rotatable table top 0.8 meter above ground.
- b. The EUT was set 10 meters from the interference-receiving antenna which was mounted on the top of a variable height antenna tower.
- c. The table was rotated 360 degrees to determine the position of the highest radiation.
- d. The antenna is a broadband antenna and its height is varied between one meter and four meters above ground to find the maximum value of the field strength both horizontal polarization and vertical polarization of the antenna are set to make the measurement.
- e. For each suspected emission the EUT was arranged to its worst case and then tune the antenna tower (from 1 M to 4 M) and turn table (from 0 degree to 360 degrees) to find the maximum reading.
- f. Set the test-receiver system to Peak Detect Function and specified bandwidth with Maximum Hold Mode.
- g. If the emission level of the EUT in peak mode was 3 dB lower than the limit specified, then testing will be stopped and peak values of EUT will be reported, otherwise, the emissions which do not have 3 dB margin will be repeated one by one using the quasi-peak method and reported.

< Above 1GHz >

- a. The EUT was placed on a turntable at the height of 0.8 meters from the ground.
- b. The EUT was set at a distance of 3 meters from the interference-receiving antenna which was mounted on the top of a variable height antenna tower.
- c. An absorber was placed between the EUT and Antenna as required per the CISPR16-1-14 standard, specifically, the measurement setup requirements defined for an accredited test site.
- d. The table was rotated 360 degrees to determine the position of the highest radiation.
- e. Set the measuring receiver system to "Peak Detection" function and "Specified Bandwidth" with the "Maximum Hold" mode set on the measuring receiver.
- f. The DRG Horn Antenna was set at a height of 1 meter while turning the turntable to obtain the EUT's most maximized operational radiation noise readings from both the "Horizontal" and "Vertical" polarizations separately.
- g. When an EUT is located on the turntable, and its height is over 172cm (when the antenna's 3dB beam width of 6GHz is at 27°), the DRG Horn Antenna must be raised and descended while turning the turntable to obtain the EUT's most maximized operational radiation noise readings from both the "Horizontal" and "Vertical" polarizations separately.

NOTE: The maximum raise height of the antenna is the same height as that of the top of the EUT while located on top of the turntable.

- h. If the emission level of the EUT in "Peak Detection" mode is 20dB lower than the "Average" limit (means that the emission level in "Peak Detection" mode also complies with the limit in "Average Mode"), testing will be stopped and "Peak" values of the EUT will be reported, otherwise, the emissions of the EUT will be measured in "Average Mode" again and then reported.

3.3.4 Test Setup Layout

< Below 1GHz >

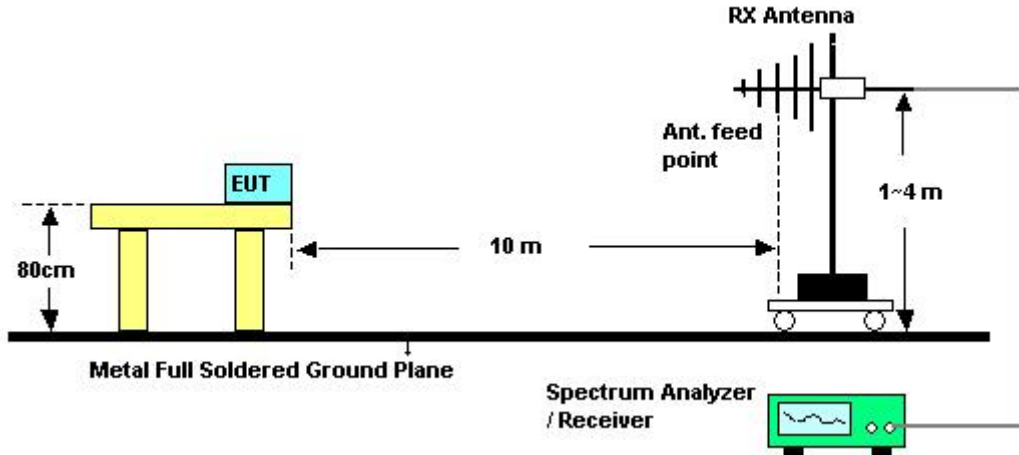

< Above 1GHz >

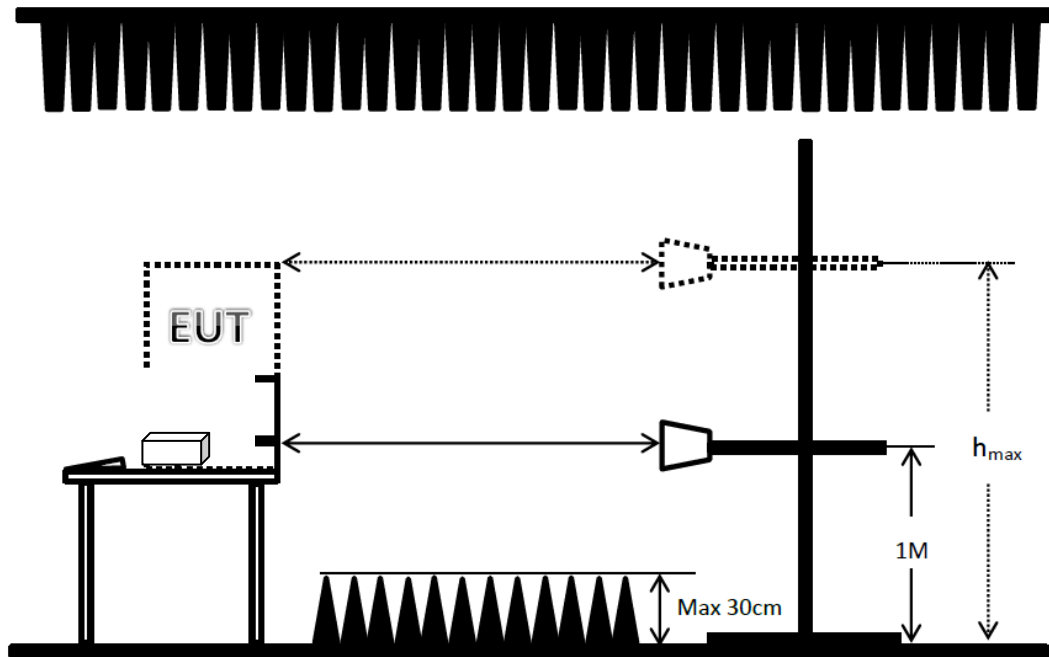

Remark: When EUT's height is over 172cm, h_{max} = top of EUT



3.3.5 Results for Radiated Emissions (30MHz~1GHz)

Final Test Date	Oct. 23, 2013	Test Site No.	10CH01-HY
Temperature	19°C	Humidity	58%
Test Engineer	Nigel		
Configuration	Mode 1. Bluetooth Mode		

Horizontal

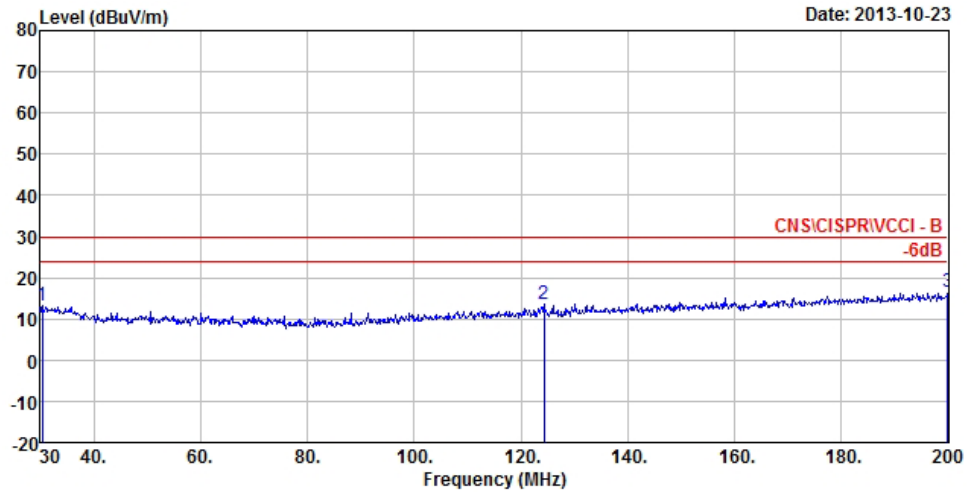

	Freq	Level	Over Limit	Limit Line	Read Level	Cable Loss	Antenna Factor	Preamp Factor	Remark	A/Pos	T/Pos
	MHz	dBuV/m	dB	dBuV/m	dBuV	dB	dB/m	dB		cm	deg
1	30.34	13.19	-16.81	30.00	27.26	1.38	13.20	28.65	Peak	---	---
2	124.35	13.70	-16.30	30.00	28.26	2.85	10.91	28.32	Peak	---	---
3 MX	200.00	16.61	-13.39	30.00	26.84	3.57	14.19	27.99	Peak	---	---

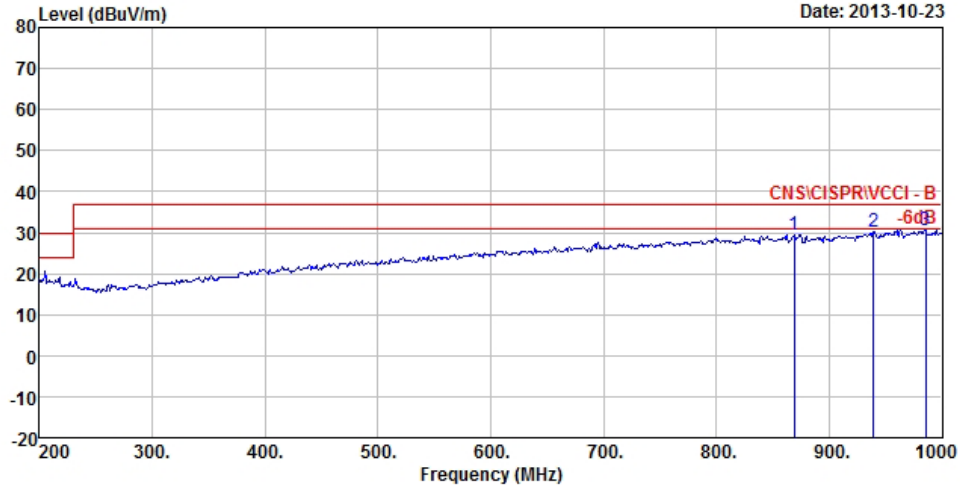

	Freq	Level	Over Limit	Limit Line	Read Level	CableAntenna Loss	Preamp Factor	Preamp Factor	Remark	A/Pos	T/Pos
	MHz	dBuV/m	dB	dBuV/m	dBuV	dB	dB/m	dB		cm	deg
1	868.80	29.42	-7.58	37.00	27.74	8.30	20.97	27.59	Peak	---	---
2	939.20	30.24	-6.76	37.00	27.64	8.49	21.41	27.30	Peak	---	---
3 MX	985.60	30.61	-6.39	37.00	27.41	8.43	21.89	27.12	Peak	100	240



Vertical

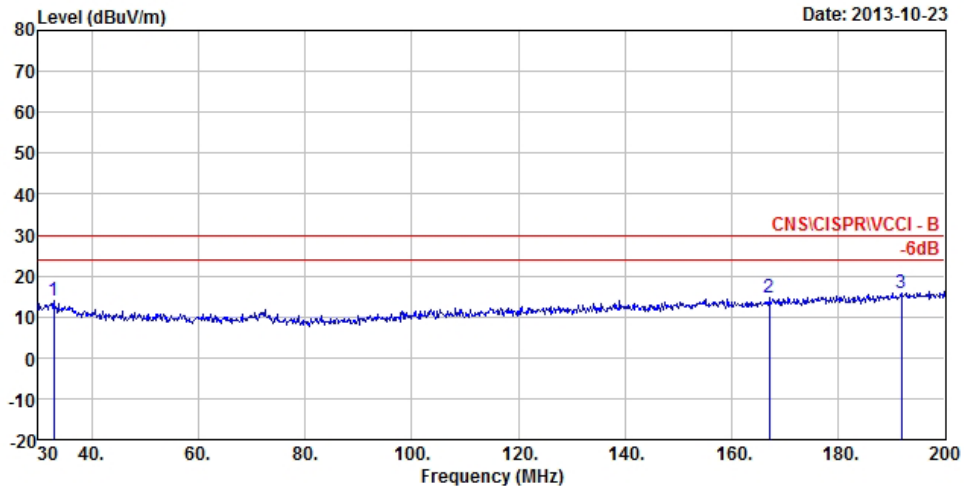

Date: 2013-10-23

	Freq	Level	Over Limit	Limit Line	Read Level	CableAntenna Loss	Preamp Factor	Preamp Factor	Remark	A/Pos	T/Pos
	MHz	dBuV/m	dB	dBuV/m	dBuV	dB	dB/m	dB		cm	deg
1	32.89	13.86	-16.14	30.00	28.11	1.45	12.94	28.64	Peak	---	---
2	167.02	14.63	-15.37	30.00	26.73	3.36	12.68	28.14	Peak	---	---
3 MX	191.84	15.96	-14.04	30.00	26.52	3.63	13.83	28.02	Peak	---	---

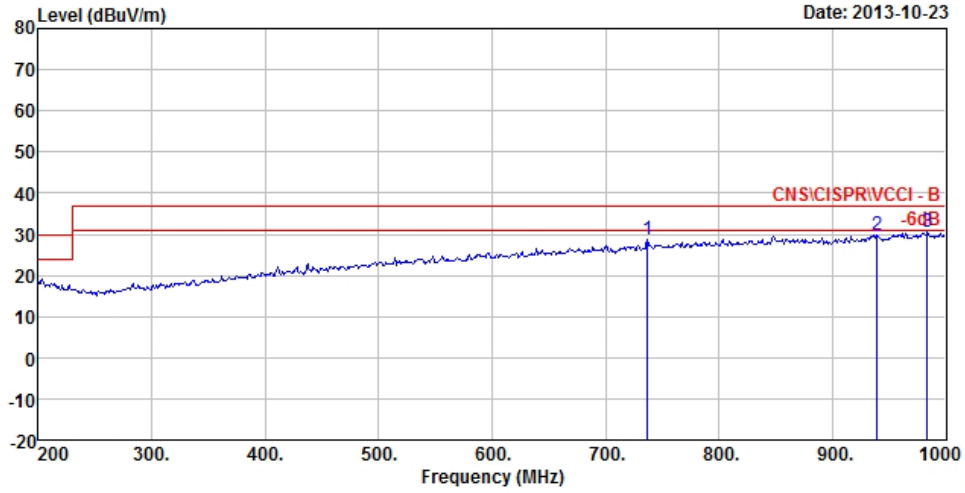

	Freq	Level	Over Limit	Limit Line	Read Level	CableAntenna Loss	Antenna Factor	Preamp Factor	Remark	A/Pos	T/Pos
	MHz	dBuV/m	dB	dBuV/m	dBuV	dB	dB/m	dB		cm	deg
1	736.80	28.60	-8.40	37.00	28.70	7.58	20.37	28.05	Peak	---	---
2	939.20	29.68	-7.32	37.00	27.08	8.49	21.41	27.30	Peak	---	---
3 MX	984.00	30.49	-6.51	37.00	27.30	8.43	21.88	27.12	Peak	---	---

Note: Corrected Reading: Antenna Factor + Cable Loss + Read Level - Preamp Factor = Level.
 V: Vertical Polarization ; H: Horizontal Polarization.



3.3.6 Results for Radiated Emissions (1GHz to 6GHz)

Final Test Date	Oct. 24, 2013	Test Site No.	03CH04-HY
Temperature	21°C	Humidity	54%
Test Engineer	Kevin		
Configuration	Mode 1. LAN 1Gbps, WLAN link		

Horizontal

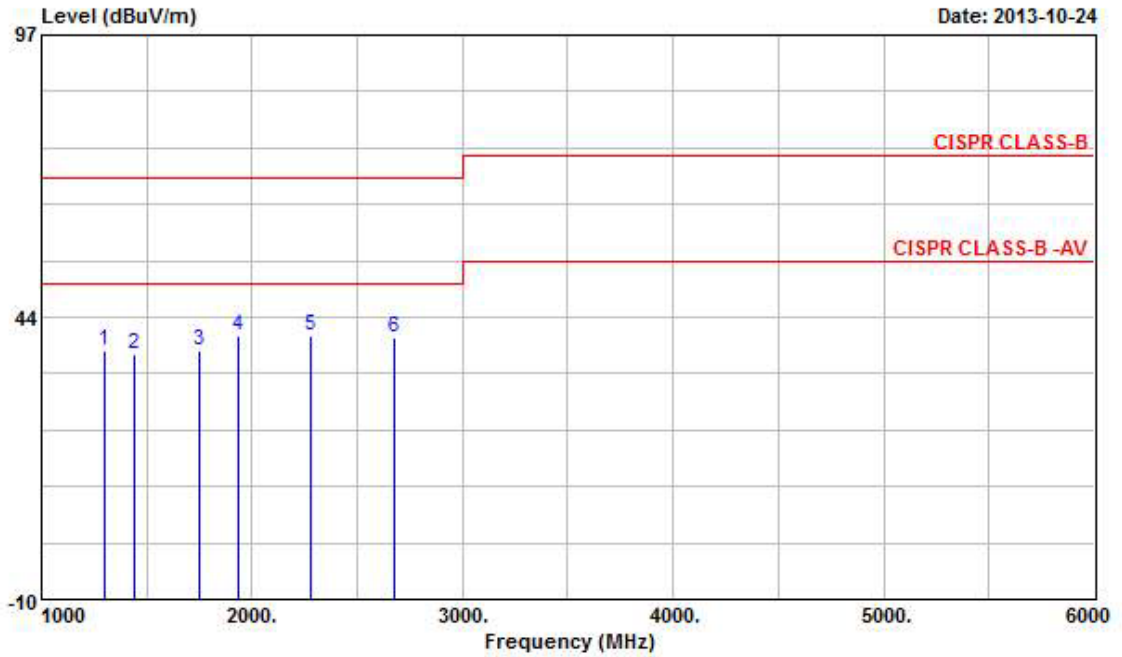

	Freq	Level	Over Limit	Limit Line	ReadAntenna Level	Antenna Factor	Preamp Factor	Cable Loss	Ant Pos	Table Pos	Remark
	MHz	dBuV/m	dB	dBuV/m	dBuV	dB/m	dB	dB	cm	deg	
1	1302.000	37.01	-32.99	70.00	42.97	25.52	34.06	2.57	---	---	Peak
2	1438.000	36.57	-33.43	70.00	42.40	25.33	33.87	2.71	---	---	Peak
3	1750.000	37.30	-32.70	70.00	42.77	25.13	33.64	3.05	---	---	Peak
4	1932.000	39.86	-30.14	70.00	44.27	25.88	33.54	3.26	---	---	Peak
5	2276.000	39.90	-30.10	70.00	42.09	27.97	33.78	3.61	---	---	Peak
6	2678.000	39.77	-30.23	70.00	41.74	28.10	34.11	4.04	---	---	Peak

Vertical

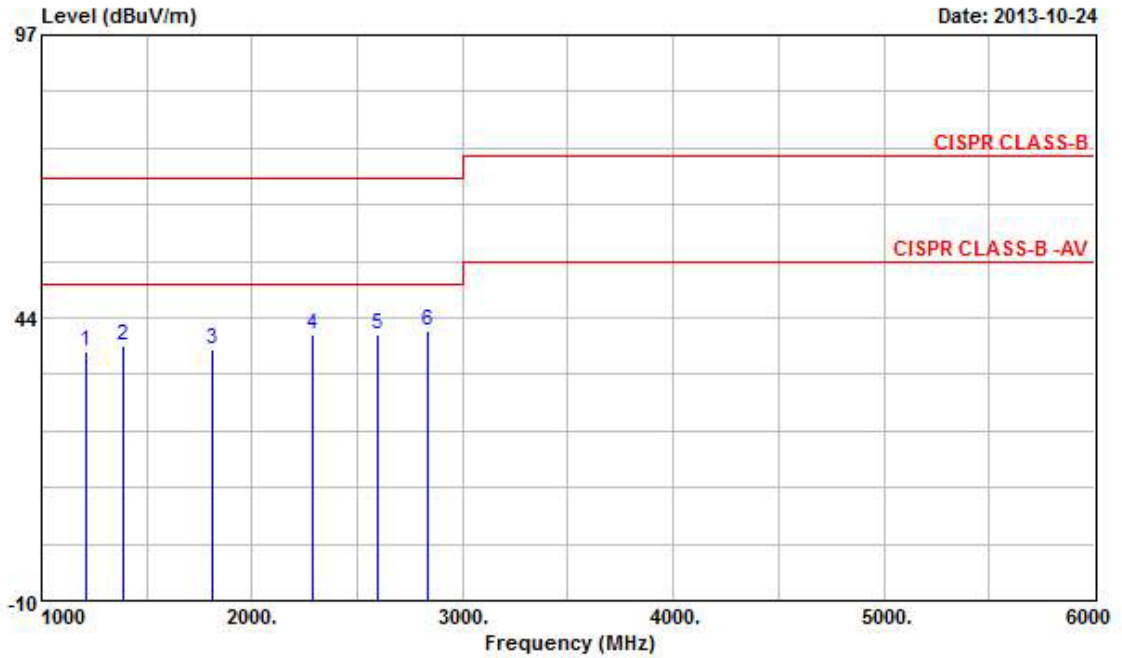

	Freq	Level	Over	Limit	ReadAntenna	Preamp	Cable	Ant	Table	Remark
	MHz	dBuV/m	dB	dBuV/m	dBuV	dB/m	dB	cm	deg	
1	1214.000	37.34	-32.66	70.00	43.98	25.10	34.21	2.47	---	Peak
2	1388.000	38.33	-31.67	70.00	44.20	25.42	33.94	2.65	---	Peak
3	1814.000	37.63	-32.37	70.00	42.76	25.35	33.60	3.13	---	Peak
4	2284.000	40.49	-29.51	70.00	42.65	27.98	33.78	3.64	---	Peak
5	2598.000	40.44	-29.56	70.00	42.74	27.80	34.06	3.96	---	Peak
6 @	2836.000	41.13	-28.87	70.00	42.73	28.43	34.21	4.19	100	117 Peak

Note: Corrected Reading: Antenna Factor + Cable Loss + Read Level - Preamp Factor = Level.
 V: Vertical Polarization ; H: Horizontal Polarization.

3.4 Harmonic Current Emissions Measurement

3.4.1 Limit

Harmonic current emissions evaluate the potential for the EUT to cause distortion on the AC power lines. It is applicable to electrical and electronic equipment having an input current ≤ 16 A per phase, and intended to be connected to public low-voltage distribution systems. EUT has been specified power less than or equal to 600 W and complies with Class D equipment and limits.

Harmonics [n]	Class A [A]	Class B [A]	Class C [% of fund]	Class D [mA/W]
Odd harmonics				
3	2.30	3.45	$30 \times \lambda$	3.4
5	1.14	1.71	10	1.9
7	0.77	1.155	7	1.0
9	0.40	0.60	5	0.5
11	0.33	0.495	3	0.35
13	0.21	0.315	3	3.85/13
$15 \leq n \leq 39$	$0.15 \times 15/n$	$0.225 \times 15/n$	3	$3.85/n$
Even harmonics				
2	1.08	1.62	2	-
4	0.43	0.645	-	-
6	0.30	0.45	-	-
$8 \leq n \leq 40$	$0.23 \times 8/n$	$0.345 \times 8/n$	-	-

3.4.2 Measuring Instruments and Setting

See list of measuring instruments of this test report.

Harmonic and Flicker Tester	Setting
Line Voltage	230 V
Line Frequency	50 Hz
Current Measurement Range	High
Measurement Delay	10.0 seconds
Test Duration	2.00 minutes

3.4.3 Test Procedures

The measurement of harmonic currents shall be performed as follows:

- for each harmonic order, measure the 1.5 s smoothed r.m.s. harmonic current in each DFT time window as defined in IEC 61000-4-7.
- calculate the arithmetic average of the measured values from the DFT time windows, over the entire observation period Short cyclic ($T_{\text{cycle}} \leq 2.5$ min). Because of synchronisation to meet the requirements for repeatability in 5%.

3.4.4 Test Setup Layout

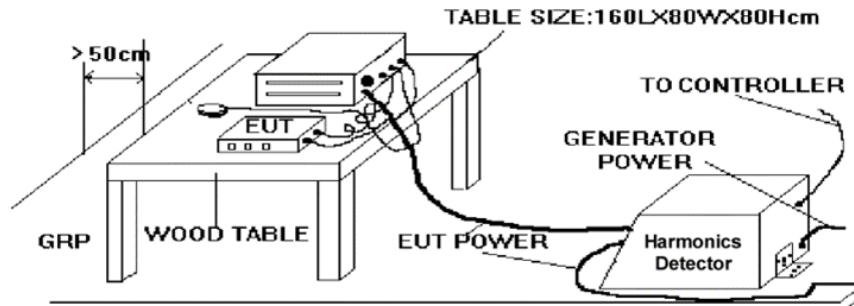

3.4.5 Test Deviation

There is no deviation with the original standard.

3.4.6 Results of Harmonic Current Emissions

The test is not applicable for this EUT.

3.5 Voltage Fluctuation and Flicker Measurement

3.5.1 Limit

The objective of voltage changes, voltage fluctuations and flicker in public low voltage supply systems during equipment with rated current ≤ 16 A per phase, ensures that home appliances and certain other electrical equipment do not adversely affect lighting equipment when connected to the same power system.

Voltage Fluctuation and Flicker Limits

- The value of P_{st} shall not be greater than 1.0.
- The value of P_{ft} shall not be greater than 0.65.
- The value of $d(t)$ during a voltage change shall not exceed 3.3 % for more than 500 ms.
- The relative steady-state voltage change, dc , shall not exceed 3.3 %.
- The maximum relative voltage change, d_{max} , shall not exceed 4.0 %.

3.5.2 Measuring Instruments and Setting

See list of measuring instruments of this test report.

Harmonic and Flicker Tester	Setting
Line Voltage	230 V
Line Frequency	50 Hz
Measurement Delay	10.0 seconds
Pst Integration Time	10 minutes
Pst Integration Periods	1

3.5.3 Test Procedures

The total impedance of the test circuit, excluding the appliance under test, but including the internal impedance of the supply source, shall be equal to the reference impedance. The stability and tolerance of the reference impedance shall be adequate to ensure that the overall accuracy of $\pm 8\%$ is achieved during the whole assessment procedure

3.5.4 Test Setup Layout

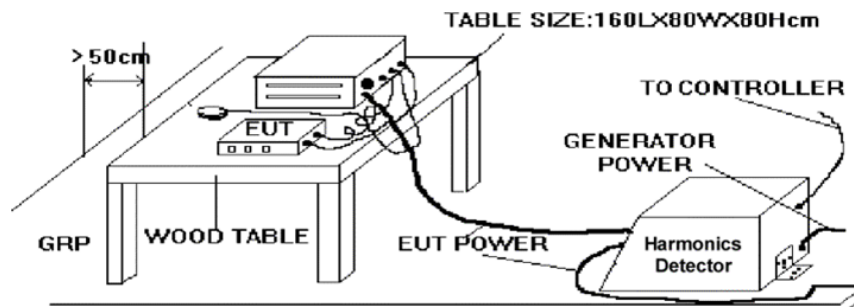

3.5.5 Test Deviation

There is no deviation with the original standard.

3.5.6 Test Result of Voltage Fluctuation and Flicker

The test is not applicable for this EUT.

4 IMMUNITY TESTS RESULT

4.1 Electrostatic Discharge Immunity Measurement (ESD)

4.1.1 Limit

Air discharges and contact charges are estimated to enclosure of EUT on all connectors and conducting surfaces.

Contact Discharges to the conductive surfaces and to coupling planes:

The EUT shall be exposed to at least 200 discharges 100 each at negative and positive polarity. One of the test points shall be subjected to at least 50 indirect discharges (contact) to the center of the front edge of the horizontal coupling plane(HCP). The remaining three test points shall each receive at least 50 direct contact discharges. If no direct contact test points are available, then at least 200 indirect discharges shall be applied in the indirect mode [see IEC 61000-4-2 for use of the Vertical Conducting Plane (VCP)]. Tests shall be performed at a maximum repetition rate of one discharge per second.

Air Discharge at seam between apertures and insulation surfaces:

On those parts of the EUT where it is not possible to perform contact discharge testing, the equipment should be investigated to identify user accessible points where breakdown may occur. This investigation should be restricted to those areas normally handled by the user. A minimum of 10 single air discharges of each polarity and test level shall be applied to the selected test point for each area.

The preferential range of test levels for the ESD test is given in following levels:

Contact discharge Test voltage ± 4 kV ; Air discharge Test voltage ± 8 kV.

4.1.2 Measuring Instruments and Setting

See list of measuring instruments of this test report.

Electrostatic Discharge Simulator	Discharge Setting
Contact Charge Voltage	$\pm 2 / \pm 4 /$
Air Charge Voltage	$\pm 2 / \pm 4 / \pm 6 / \pm 8$ kV
Rise Time	0.8ns + 25%
Half-Value width	30nS + 30%
Polarity	Positive/Negative
Single Discharge Mode	1 discharge per 1s

4.1.3 Test Procedures

- In the case of air discharge testing the climatic conditions shall be within the following ranges:
 - ambient temperature: 15°C to 35°C;
 - relative humidity : 30% to 60%;
 - atmospheric pressure : 86 kPa (860 mbar) to 106 kPa (1060 mbar).
- Test programs and software shall be chosen so as to exercise all normal modes of operation of the EUT. The use of special exercising software is encouraged, but permitted only where it can be shown that the EUT is being comprehensively exercised.
- The test voltage shall be increased from the minimum to the selected test severity level, in order to determine any threshold of failure. The final severity level should not exceed the product specification value in order to avoid damage to the equipment.
- The test shall be performed with both air discharge and contact discharge. On preselected points at least 10 single discharges (in the most sensitive polarity) shall be applied on air discharge. On preselected points at least 10 single discharges (in the most sensitive polarity) shall be applied on contact discharge.
- For the time interval between successive single discharges an initial value of one second is recommended. Longer intervals may be necessary to determine whether a system failure has occurred.

6. In the case of contact discharges, the tip of the discharge electrode shall touch the EUT before the discharge switch is operated.
7. In the case of painted surface covering a conducting substrate, the following procedure shall be adopted :
 - If the coating is not declared to be an insulating coating by the equipment manufacturer, then the pointed tip of the generator shall penetrate the coating so as to make contact with the conducting substrate.
 - Coating declared as insulating by the manufacturer shall only be submitted to the air discharge.
 - The contact discharge test shall not be applied to such surfaces.
8. In the case of air discharges, the round discharge tip of the discharge electrode shall be approached as fast as possible (without causing mechanical damage) to touch the EUT. After each discharge, the ESD generator (discharge electrode) shall be removed from the EUT. The generator is then retriggered for a new single discharge. This procedure shall be repeated until the discharges are completed. In the case of an air discharge test, the discharge switch, which is used for contact discharge, shall be closed.

4.1.4 Test Setup

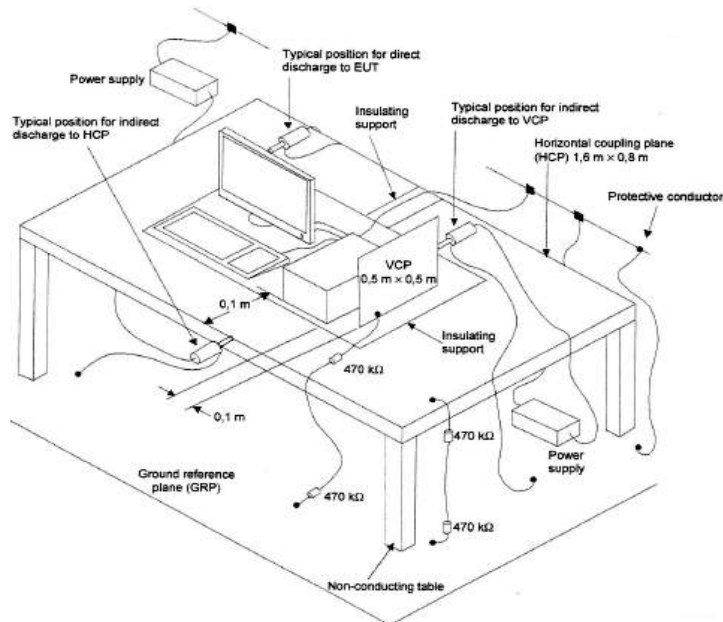

setup consists of the test generator, EUT and auxiliary instrumentation necessary to perform DIRECT and INDIRECT application of discharges to the EUT as applicable, in the follow manner :

- a. CONTACT DISCHARGE to the conductive surfaces and to coupling plane;
- b. AIR DISCHARGE at insulating surfaces.

The preferred test method is that of type tests performed in laboratories and the only accepted method of demonstrating conformance with this standard. The EUT was arranged as closely as possible to arrangement in final installed conditions.



4.1.5 Test Result of Electrostatic Discharge Immunity

Final Test Date	Oct. 23, 2013	Pressure	99 kPa
Temperature	23°C	Test Engineer	Jaily
Humidity	43%	Configuration	Mode 1
Required Performance Criteria	<u>B</u>	Pass Performance Criteria	<u>A</u>

Test Result of Contact Discharge

Indirect discharge to HCP and VCP

Test Point	No. Of Discharges	Contact Discharge / Pointed Tip				Test Record
		+2kV	-2kV	+4kV	-4kV	
HCP (At Front)	10	A	A	A	A	None
HCP (At Left)	10	A	A	A	A	None
HCP (At Right)	10	A	A	A	A	None
HCP (At Rear)	10	A	A	A	A	None
VCP (At Front)	10	A	A	A	A	None
VCP (At Left)	10	A	A	A	A	None
VCP (At Right)	10	A	A	A	A	None
VCP (At Rear)	10	A	A	A	A	None

Test Result of Air Discharge

Test Point	No. Of Discharges	Contact Discharge / Pointed Tip								Test Record
		+2kV	-2kV	+4kV	-4kV	+6kV	-6kV	+8kV	-8kV	
Case	10	A	A	A	A	A	A	A	A	None
LED	10	A	A	A	A	A	A	A	A	None

4.2 Radio Frequency Electromagnetic Field Immunity Measurement (RS)

4.2.1 Limit

Most electronic equipment is in some manner affected by electromagnetic radiation. RF immunity test entails subjecting the equipment under test to a uniform field of radiated electromagnetic energy of a specified electromagnetic field strength and frequency and monitoring the functionality of the device as the frequency is swept over a specified frequency range.

The preferential range of test field strength levels for the RS test is given in following levels:
80~1GHz 3V/m; 1.4~2.7GHz: 3V/m.

4.2.2 Exclusion Bands

Using the 2,450 MHz band as an example:

- lower limit of exclusion band = 2400 - 120 = 2280 MHz;
- upper limit of exclusion band = 2483,5 + 124,175 = 2607,675 MHz;
- thus the exclusion band for 2,45 GHz equipment falling within the scope of the present document extends from 2280 MHz to 2607,675 MHz.

4.2.3 Measuring Instruments and Setting

See list of measuring instruments of this test report.

RS Immunity Test System	Setting
Method Used	Bilog antenna and Horn antenna
Field Strength Exposure	3 V/m (measured un-modulated carrier)
Frequency Range/Modulation	80 MHz to 1000 MHz and 1400 MHz to 2700 MHz, 80% AM modulation
Antenna Polarization	Vertical & Horizontal
Test Distance	3m
Frequency Steps	1% step
Dwell Time	2.9 sec
Exposures	Front, Back, Left and Right of the EUT

4.2.4 Test Procedures

1. The equipment to be tested is placed in the center of the enclosure on a wooden table. The equipment is then connected to power and signal leads according to pertinent installation instructions.
2. The bilog antenna which is enabling the complete frequency range of 80 MHz to 1000 MHz and 1400 MHz to 2700 MHz is placed 3m away from the equipment. The required field strength is determined by placing the field strength meter(s) on top of or directly alongside the equipment under test and monitoring the field strength meter via a remote field strength indicator outside the enclosure while adjusting the continuous-wave to the applicable antennae.
3. The test is normally performed with the generating antenna facing each of four sides of the EUT. The polarization of the field generated by the bi-conical antenna necessitates testing each position twice, once with the antenna positioned vertically and again with the antenna positioned horizontally. The circular polarization of the field from the log-spiral antenna makes a change of position of the antenna unnecessary.
4. At each of the above conditions, the frequency range is swept 80 MHz to 1000 MHz and 1400 MHz to 2700 MHz pausing to adjust the R.F. signal level or to switch oscillators and antenna. The rate of sweep is in the order of 1.5×10^{-3} decades/s. The sensitive frequencies or frequencies of dominant interest may be discretely analyzed.

4.2.5 Test Severity Levels

Frequency Band : 80MHz to 2,700 MHz

Level	Test Field Strength (V/m)
1	1
2	3
3	10
X	Specified

Remark : "X" is an open class.

4.2.6 Test Setup Layout

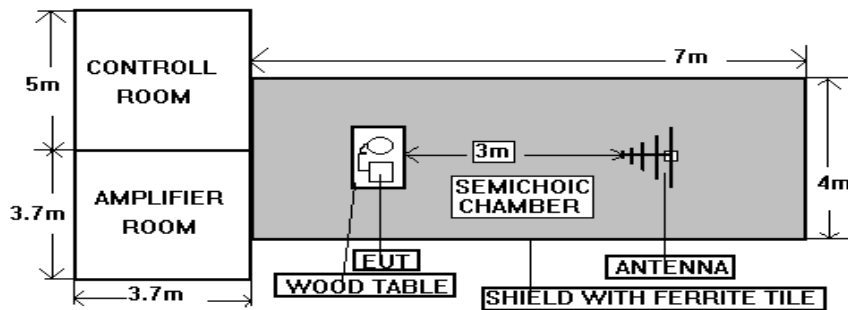

NOTE : The SPORTON 7m x 4m x 4m semichoice chamber is compliance with the sixteen points uniform field requirement as stated in IEC 61000-4-3 Section 6.2.

The procedure defined in this part requires the generation of electromagnetic fields within which the test sample is placed and its operation observed. To generate fields that are useful for simulation of actual (field) conditions may require significant antenna drive power and the resultant high field strength levels. To comply with local regulations and to prevent biological hazards to the testing personnel, it is recommended that these tests be carried out in a shielded enclosure or semichoice chamber.



4.2.7 Test Result of Radio Frequency Electromagnetic Field Immunity

Final Test Date	Oct. 23, 2013	Pressure	99 kPa
Temperature	22°C	Test Engineer	Jaily
Humidity	43%	Configuration	Mode 1
Required Performance Criteria	<u>A</u>	Pass Performance Criteria	<u>A</u>

Sides of the EUT have been exposed to the field	Antenna positioned	Test field strength Level	Test field strength (V/m)	Observation
Front	Vertical	2	3	Normal (No influencing)
	Horizontally	2	3	
Left	Vertical	2	3	Normal (No influencing)
	Horizontally	2	3	
Back	Vertical	2	3	Normal (No influencing)
	Horizontally	2	3	
Right	Vertical	2	3	Normal (No influencing)
	Horizontally	2	3	

4.3 Electrical Fast Transient/Burst Immunity Measurement (EFT)

4.3.1 Limit

This test interference signal injects to the AC/DC power supply and signal I/O lines of the EUT.

Test on Power Line:

The EFT/B-generator was located on the GRP. The length from the EFT/B-generator to the EUT as not exceeds 1 m.

The EFT/B-generator provides the ability to apply the test voltage in a non-symmetrical condition to the power supply input terminals of the EUT.

The preferential range of test peak voltage levels for the EFT test is given in following levels:

Power Line: ±1kV; Telecommunication Lines: ±0.5kV.

4.3.2 Measuring Instruments and Setting

See list of measuring instruments of this test report.

EMC Test Station (EFT)	Setting
Test Voltage	Power Line: ±1kV ; Signal, telecommunication ports: ±0.5kV
Polarity	Positive/Negative
Impulse Frequency	5 kHz
Impulse Wave shape (T _r /T _h)	5/50 ns
Burst Duration	15 ms

4.3.3 Test Procedures

- In order to minimize the effect of environmental parameters on test results, the climatic conditions when test is carrying out shall comply with the following requirements:
 ambient temperature: 15°C to 35°C;
 relative humidity : 10% to 75%;
 atmosphJaily pressure : 86 kPa (860 mbar) to 106 kPa (1060 mbar).
- In order to minimize the effect of environmental parameters on test results, the electromagnetic environment of the laboratory shall not influence the test results.
- The variety and diversity of equipment and systems to be tested make it difficult to establish general criteria for the evaluation of the effects of fast transients/bursts on equipment and systems.
- The test results may be classified on the basic of the operating conditions and the functional specification of the equipment under test, according to the following performance criteria:
 -Normal performance within the specification limits.
 -Temporary degradation or loss of function or performance which is self-recoverable.
 -Temporary degradation or loss of function or performance which requires operator intervention or system reset.
 -Degradation or loss of function which is not recoverable due to damage of equipment (components).

4.3.4 Test Severity Levels

The following test severity levels are recommended for the fast transient/burst test :

Open Circuit Output Test Voltage $\pm 10\%$		
Level	On Power Supply	On I/O Signal, Data and Control Line
1	0.5 kV	0.25 kV
2	1.0 kV	0.50 kV
3	2.0 kV	1.00 kV
4	4.0 kV	2.00 kV
X	Specified	Specified

Remark : " X " is an open level. The level is subject to negotiation between the user and the manufacturer or is specified by the manufacturer.

4.3.5 Test Setup Layout

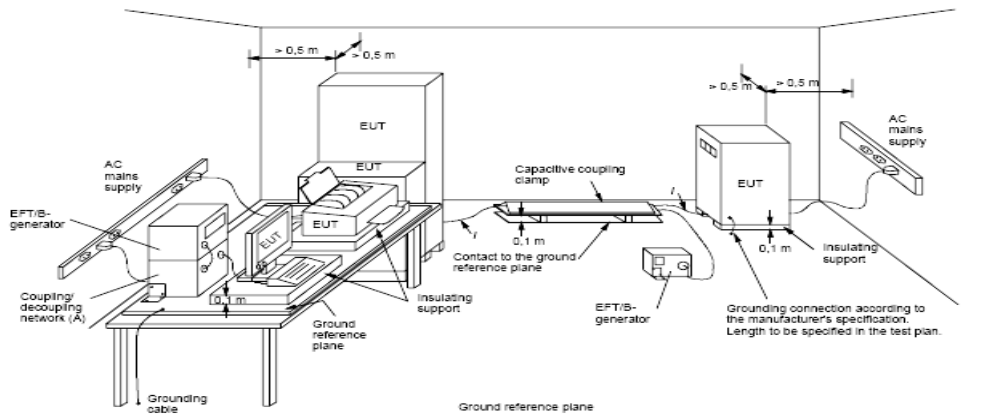

- Key**
- / length between clamp and the EUT to be tested (should be 0,5 m \pm 0,05 m)
 - (A) location for supply line coupling
 - (B) location for signal lines coupling

IEC 901/04

The EUT was placed on a ground reference plane and was insulated from it by an insulating support about 0.1m thick. If the EUT is table-top equipment, it was located approximately 0.8m above the GRP. The GRP. Was a metallic sheet of 0.25 mm, minimum thickness; other metallic may be used but they shall have at least 0.65 mm thickness. It shall project beyond the EUT by at least 0.1m on all sides and connected to the protective earth. In the SPORTON EMC LAB. We provided 1 mm thickness aluminum ground reference plane or 1 mm thickness stainless steel ground reference plane. The minimum size of the ground reference plane is 1 m x 1 m, the exact size depending on the dimensions of the EUT. It was connected to the protective grounding system. The EUT was arranged and connected according to its functional requirements. The minimum distance between the EUT and other conductive structures, except the GRP. Beneath the EUT, was more than 0.5 m. using the coupling clamp, the minimum distance between the coupling plates and all other conductive structures, except the GRP. Beneath the EUT, was more than 0.5 m. The length of the signal and power lines between the coupling device and the EUT was 1m or less.

4.3.6 Test Deviation

There is no deviation with the original standard.

4.3.7 Test Result of Electrical Fast Transient/Burst Immunity

The test is not applicable for this EUT.

4.4 Surge Immunity Measurement (Surge)

4.4.1 Limit

This test simulates a lightning event by inducing transients onto the AC/DC power supply lines in common and differential mode.

Each device was tested in a total of two surge Configuration:

Line to Ground (L-G): Combination Wave, Line to Protective Earth with 9uF and 10Ohm and Neutral to Protective Earth with 9uF and 10Ohm, common mode, generator earthed.

Line-to-Line (L-L): Combination Wave, Line to Neutral with 18uF, differential mode, generator floated.

The preferential range of test peak voltage levels for the Surge test is given in following levels:

AC/DC power Line: Line to line: ±1kV; Line to ground: ±2kV;

Outdoor Telecommunication Line: Line to ground: ±1kV;

Indoor Telecommunication Line: Line to ground: ±0.5kV.

4.4.2 Measuring Instruments and Setting

See list of measuring instruments of this test report.

EMC Test Station (Surge)	Setting
Combination Wave Shape	1.2/50us Open Circuit Voltage; 8/20us Short Circuit Current
Power Line Test Voltage	Line to line ±1kV; Line to ground ±2kV
Telecom Lines Test Voltage	Outdoor Line to ground ±1kV; Indoor Line to ground: ±0.5kV
Polarity	Positive/Negative
Phase Angle	0° /90°/180°/270°
Pulse Repetition Rate	1 time / min. (maximum)
Number of Tests	5 positive and 5 negative at selected points

4.4.3 Test Procedures

1. The climatic conditions shall comply with the following requirements :
 - ambient temperature : 15 °C to 35 °C
 - relative humidity : 10 % to 75 %
 - atmospherically pressure : 86 kPa to 106 kPa (860 mbar to 1060 mbar)
2. Electromagnetic conditions, the electromagnetic environment of the laboratory shall not influence the test results.
3. The test shall be performed according the test plan that shall specify the test set-up with
 - generator and other equipment utilized;
 - test level (voltage/current);
 - generator source impedance;
 - internal or external generator trigger;
 - number of tests: at least five positive and five negative at the selected points;
 - repetition rate: maximum 1/min.
 - inputs and outputs to be tested;
 - representative operating conditions of the EUT;
 - sequence of application of the surge to the circuit;
 - phase angle in the case of AC power supply;
 - actual installation conditions, for example :
 - AC : neutral earthed,
 - DC : (+) or (-) earthed to simulated the actual earth conditions.
4. If not otherwise specified the surges have to be applied synchronized to the voltage phase at the zero crossing and the peak value of the a.c. voltage wave (positive and negative).
5. The surges have to be applied line to line and line(s) and earth. When testing line to earth, the test voltage has to be applied successively between each of the lines and earth, if there is no other specification.

6. The test procedure shall also consider the non-linear current-voltage characteristics of the equipment under test. Therefore the test voltage has to be increased by steps up to the test level specified in the product standard or test plan.
7. All lower levels including the selected test level shall be satisfied. For testing the secondary protection, the output voltage of the generator shall be increased up to the worst-case voltage breakdown level (let-through level) of the primary protection.
8. If the actual operating signal sources are not available, they may be simulated. Under no circumstances may the test level exceed the product specification. The test shall be carried out according to the test plan.
9. To find all critical points of the duty cycle of the equipment, a sufficient number of positive and negative test pulses shall be applied. For acceptance test previously unstressed equipment shall be used to the protection devices shall be replaced.

4.4.4 Test Level

Level	Open-Circuit Test Voltage, $\pm 10\%$, kV
1	0.5
2	1.0
3	2.0
4	4.0
x	Specified

NOTE - x is an open class.
This level can be specified in the product specification.

4.4.5 Test Setup Layout

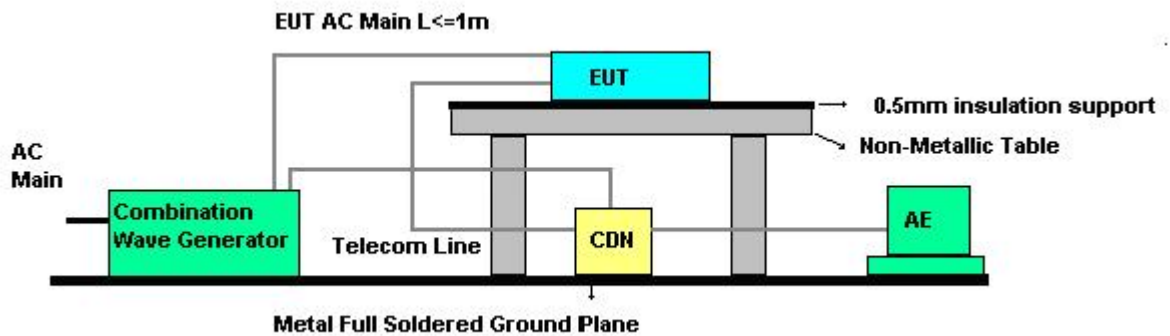

4.4.6 Test Deviation

There is no deviation with the original standard.

4.4.7 Test Result of Surge Immunity

The test is not applicable for this EUT.

4.5 Conducted Disturbances Induced by RF Field Immunity Measurement (CS)

4.5.1 Limit of Conducted Disturbances Induced by RF Field Immunity (CS)

This test assesses the ability of the EUT to operate as intended in the presence of a radio frequency electromagnetic disturbance on the input/output ports.

The preferential range of test field strength levels for the CS test is given in following levels:
150 kHz ~ 80 MHz: 3 Vrms.

4.5.2 Measuring Instruments

See list of measuring instruments of this test report.

CS Immunity Test System	Setting
Field Strength Exposure	3Vrms
Frequency Range/Modulation	150kHz~80MHz, 80% AM modulation
Frequency Steps	1% step
Dwell Time	2.9 sec

4.5.3 Test Procedures

1. This test method test can be performed without using a self-shielded enclosure. This is because the disturbance levels applied and the geometry of the setups are not likely to radiated a high amount of energy, especially at the lower frequencies. If under certain circumstances the radiated energy is too high, a shielded enclosure has to be used.
2. The test shall be performed with the test generator connected to each of the coupling and decoupling devices in turn while the other non-excited RF-input ports of the coupling devices are terminated by a 50-ohm load resistor.
3. The frequency range is swept from 150 kHz to 80 MHz, using the signal levels established during the setting process, and with the disturbance signal 80% amplitude modulated with a 1kHz sine wave, pausing to adjust the RF-signal level or to switch coupling devices as necessary. The rate of sweep shall no exceed 1.5×10^{-3} decades/s. where the frequency is swept incrementally; the step size shall no exceed 1% of the start and thereafter 1% of the preceding frequency value.
4. The dwell time at each frequency shall not be less than the time necessary for the EUT to be exercised, and able to respond. Sensitive frequencies e.g. clock frequencies and harmonics or frequencies of dominant interest shall be analyzed separately.
5. In cases of dispute, the test procedure using a step size not exceeding 1% of the start and thereafter 1% of preceding frequency value shall take precedence.

4.5.4 Test Level

Level	Voltage Level (EMF)
1	1 V rms
2	3 V rms
3	10 V rms
x	Specified
NOTE - x is an open class. This level can be specified in the product specification.	

4.5.5 Test Setup Layout

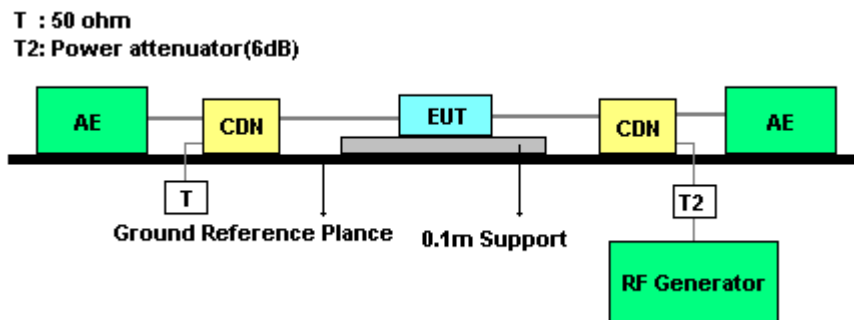

4.5.6 Test Deviation

There is no deviation with the original standard.

4.5.7 Test Result of Conducted Disturbances Induced by RF Field Immunity

The test is not applicable for this EUT.

4.6 Voltage Dips and Voltage Interruption Immunity Measurement (DIP)

4.6.1 Limit

Voltage failures occur following switching operations, short-circuits, response of fuses and when running up heavy loads. The following table is the limits of the dips and Interruption Immunity Test.

EN 301 489-1 V1.9.2 (2011-09) Voltage Dips and Voltage Interruption Performance Criteria			
Item	Residual Voltage	Residual Voltage Cycle	Performance Criteria
Voltage Dip	0 %	0.5 (10 ms)	TT, TR
Voltage Dip	0 %	1 (20 ms)	TT, TR
Voltage Dip	70 %	25 (500 ms)	TT, TR
Voltage Interruption	0 %	250 (5000 ms)	TT, TR
<p>This test shall be performed on AC power ports. For a voltage interruption the following performance criteria apply:</p> <ul style="list-style-type: none"> ◆ In the case where the EUT is fitted with a battery back-up, the performance criteria for transient phenomena for transmitters or for receivers shall apply (see clause 6 of the relevant part of EN 301 489 series dealing with the particular type of radio equipment); ◆ In the case where the EUT is powered solely from the AC mains supply (without the use of a parallel battery back-up) volatile user data may have been lost and if applicable the communication link need not to be maintained and lost functions should be recoverable by user or operator; ◆ No unintentional responses shall occur at the end of the test; ◆ In the event of loss of function(s) or in the event of loss of user stored data, this fact shall be recorded in the test report; 			

4.6.2 Measuring Instruments and Setting

See list of measuring instruments of this test report.

EMC Test Station (Dip Interruption)	Setting
Voltage Reduction (Periods)	0 % (10/20 ms); 70 % (500 ms); 0 % (5000 ms)
Test Interval	10 sec for each event

4.6.3 Test Procedures

1. The climatic conditions shall comply with the following requirements :
 - ambient temperature : 15 °C to 35 °C
 - relative humidity : 10 % to 75 %
 - atmospheric pressure : 86 kPa to 106 kPa (860 mbar to 1060 mba)
2. The EUT is powered up to a nominal voltage of 240VAC/50Hz and 100VAC/50Hz, and then software-controlled voltage dips and interruptions are introduced.

4.6.4 Test Setup Layout

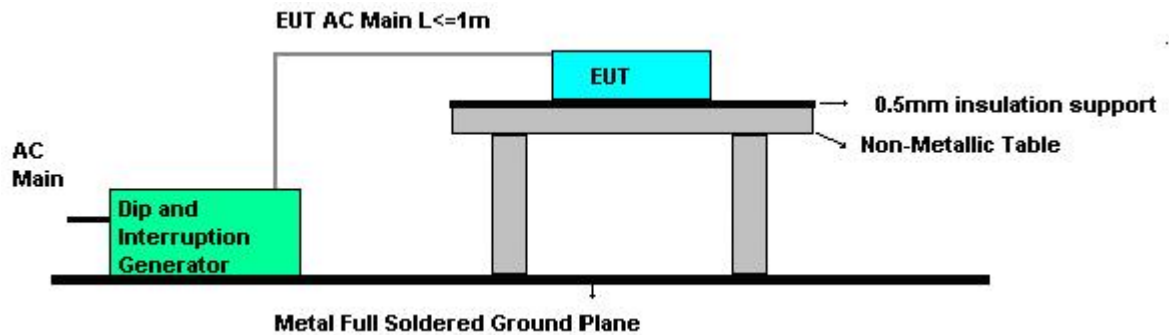

4.6.5 Test Deviation

There is no deviation with the original standard.

4.6.6 Test Result of Voltage Dips and Voltage Interruption Immunity

The test is not applicable for this EUT.



5 UNCERTAINTY

For EMI

Test Items	Test Site No.	Uncertainty	Remark
Radiated Emissions below 1GHz	10CH02-HY	± 2.82dB	Confidence levels of 95%
Radiated Emissions above 1GHz	03CH04-HY	± 4.83dB	Confidence levels of 95%

For EMS

- ESD Immunity (IEC 61000-4-2)
Negative Discharge Current

From Standard			
2kV	First Peak Current	Current at 30ns	Current at 60ns
Nominal	7.5	4	2
Min	6.75	2.8	1.4
Max	8.25	5.2	2.6
Tolerance in %	10%	30%	30%

From Calibration Certificate					
Measured First Peak Current	1st Peak Worst Case. +5%	Measured Current at 30ns	30ns Worst Case. +5%	Measured Current at 60ns	60ns Worst Case. -5%
7.48	7.85	4.2	4.41	2.01	2.11
---	6.75	---	2.8	---	1.4
---	8.25	---	5.2	---	2.6

4kV	First Peak Current	Current at 30ns	Current at 60ns
Nominal	15	8	4
Min	13.5	5.6	2.8
Max	16.5	10.4	5.2
Tolerance in %	10%	30%	30%

First Peak Current	1st Peak Worst Case. +5%	Measured Current at 30ns	30ns Worst Case. +5%	Measured Current at 60ns	60ns Worst Case. +5%
15.12	15.88	8.03	8.43	3.68	3.86
---	13.5	---	5.6	---	2.8
---	16.5	---	10.4	---	5.2

6kV	First Peak Current	Current at 30ns	Current at 60ns
Nominal	22.5	12	6
Min	20.25	8.4	4.2
Max	24.75	15.6	7.8
Tolerance in %	10%	30%	30%

First Peak Current	1st Peak Worst Case. -5%	Measured Current at 30ns	30ns Worst Case. +5%	Measured Current at 60ns	60ns Worst Case. +5%
22.78	23.92	12.37	12.99	5.45	5.72
---	20.25	---	8.4	---	4.2
---	24.75	---	15.6	---	7.8



From Standard			
8kV	First Peak Current	Current at 30ns	Current at 60ns
Nominal	30	16	8
Min	27	11.2	5.6
Max	33	20.8	10.4
Tolerance in %	10%	30%	30%

From Calibration Certificate					
First Peak Current	1st Peak Worst Case. +5%	Measured Current at 30ns	30ns Worst Case. +5%	Measured Current at 60ns	60ns Worst Case. +5%
30.26	31.77	16.13	16.94	7.39	7.76
---	27	---	11.2	---	5.6
---	33	---	20.8	---	10.4

Negative Discharge Voltage

Standard Parameters			
Indicated Voltage (kV)	Tolerance (%)	Max. (kV)	Min. (kV)
2	10	2.20	1.80
4	10	4.40	3.60
6	10	6.60	5.40
8	10	8.80	7.20
15	10	16.50	13.50

Measured Values (kV)
2.05
4.027
5.955
7.916
14.839

Negative Rise Time

Standard Parameters	
T max.	1ns
T min	0.7ns

Measured Values			
Indicated Voltage	Measured Rise Time	Worst Case Max. +6%	Worst Case Min. -6%
2kV	0.851	0.902	0.799
4kV	0.780	0.827	0.733
6kV	0.750	0.795	0.705
8kV	0.772	0.818	0.726

It has been demonstrated that the ESD generator meets the specified requirements in the standard with at least a 95% confidence.



● **RF Radiated Immunity (IEC 61000-4-3)**

Symbol	Source of Uncertainty	Value	Probability Distribution	Divisor	$u(y)$
F_{SM}	Felds Strength monitor	1.5	Normal 2	2.000	0.75
FS_{AW}	Field Strength acceptability window	0.50	Rectangular	1.732	0.29
PAH	Power Amplifier Harmonics	0.50	Rectangular	1.732	0.29
R_S	Measurement System Repeatability	0.50	normal 1	1.000	0.50
R_{EUT}	Repeatability of EUT	0.00	normal 1	1.000	0.00
$u_c(F_S)$	Combined Standard Uncertainty		normal		0.83
$U(F_S)$	Expanded Uncertainty		normal k= 2		1.66

Specified Level (V/m)	Test level (V/m)
For 1 Volts	1.25
For 3 Volts	3.33
For 10 Volts	11.22



6 LIST OF MEASURING EQUIPMENTS

<EMI>

< Radiated Emission below 1GHz >

Instrument	Manufacturer	Model No.	Serial No.	Characteristics	Calibration Date	Remark
10m Semi Anechoic Chamber	SIDT FRANKONIA	SAC-10M	10CH01-HY	30MHz ~ 1GHz 10m/3m	Jun. 10, 2013	Radiation (10CH01-HY)
Spectrum Analyzer	R&S	FSP7	838858/013	9kHz ~ 7GHz	Feb. 21, 2013	Radiation (10CH01-HY)
Receiver	R&S	ESI7	838496/009	20Hz ~ 7GHz	Jul. 23, 2013	Radiation (10CH01-HY)
Amplifier	Agilent	8447D	2944A10825	100kHz ~ 1.3GHz	Apr. 19, 2013	Radiation (10CH01-HY)
Amplifier	Agilent	8447D	2944A10826	100kHz ~ 1.3GHz	Apr. 12, 2013	Radiation (10CH01-HY)
Biconical Antenna	Schwarz beck	VHBB 9124	286	30MHz ~ 200MHz	Aug. 02, 2013	Radiation (10CH01-HY)
Log Antenna	Schwarz beck	VUSLP 9111	206	200MHz ~ 1GHz	Aug. 02, 2013	Radiation (10CH01-HY)
Turn Table	HD	DT 60 RPS	1513/004/00	0 ~ 360 degree	N/A	Radiation (10CH01-HY)
Antenna Mast	HD	MA240	240/556/00	1 ~ 4 m	N/A	Radiation (10CH01-HY)
Antenna Mast	HD	MA240	240/559/00	1 ~ 4 m	N/A	Radiation (10CH01-HY)
RF Cable-R10m	BELDEN	RG8/U	CB023-INSIDE	30MHz ~ 1GHz	Nov. 15, 2012	Radiation (10CH01-HY)
RF Cable-R10m	Suhner Switzerland + Rosenberger	RG223/U + UAA220A-0	CB022-DOOR	30MHz ~ 1GHz	Nov. 15, 2012	Radiation (10CH01-HY)

Note: Calibration Interval of instruments listed above is one year.



< Radiated Emission above 1GHz >

Instrument	Manufacturer	Model No.	Serial No.	Characteristics	Calibration Date	Remark
3m Semi Anechoic Chamber	TDK	SAC-3M	03CH04-HY	1 GHz ~ 6 GHz 3m	May. 17, 2013	Radiation (03CH04-HY)
Spectrum Analyzer	R&S	FSP40	100004	9 kHz ~ 40 GHz	Mar. 11, 2013	Radiation (03CH04-HY)
Amplifier	Agilent	8449B	3008A02326	1 GHz ~ 26.5 GHz	May. 17, 2013	Radiation (03CH04-HY)
Horn Antenna	SCHWARZBECK	BBHA9120	BBHA9120D1130	1 GHz ~ 18 GHz	Sep.10, 2013	Radiation (03CH04-HY)
Turn Table	Chaintek	3000	-	0 ~ 360 degree	NCR	Radiation (03CH04-HY)
Antenna Mast	Chaintek	-	-	1 m ~ 4 m	NCR	Radiation (03CH04-HY)
RF Cable-HIGH	SUHNER	SUCOFLEX 106	CB063-HF	1 GHz ~ 40 GHz	Nov. 21, 2012	Radiation (03CH04-HY)

Note: Calibration Interval of instruments listed above is one year.

< EMS >

Instrument	Manufacturer	Model No.	Serial No.	Characteristics	Calibration Date	Remark
ESD Simulator	KEYTEK	MZ-15/EC	0711355	Air: 0 ~15kV Contact: 0 ~ 8kV	Apr. 15, 2013	ESD

Note: Calibration Interval of instruments listed above is one year.

< RS > -- From 80 MHz to 2,700 MHz test

Instrument	Manufacturer	Model No.	Serial No.	Characteristics	Calibration Date	Remark
Amplifier	AR	250W 1000AM	0332909	80MHz ~ 1GHz	Mar. 06, 2013	RS
Amplifier	AMPLIFIER& RESEARCH	30S1G3	312505	800M~3GHz	Oct. 04, 2013	RS
DUAL DIRECTIONAL COUPLER	AMPLIFIER& RESEARCH	DC6180A	312453	0.08 ~ 1GHz	Oct. 07, 2013	RS
DUAL DIRECTIONAL COUPLER	AMPLIFIER& RESEARCH	DC7144A	312782	0.8 ~ 4.2GHz	Oct. 04, 2013	RS
INTEGRATED MEASUREMENT SYSTEM	ROHDE& SCHWARZ	IMS	100007	9kHz ~ 3GHz	Mar. 14, 2013	RS
NRP-Z91 POWER SENSOR 6GHZ	ROHDE& SCHWARZ	NRP-Z91 1168.8004.02	100095	9kHz ~ 3GHz	Mar. 14, 2013	RS
Antenna	FRANKONIA	BTA-L	02002L	26MHz ~ 1GHz	May 06, 2013	RS
Antenna	AR	AT4002A	312601	800MHz ~ 5GHz	May 06, 2013	RS
Probe	ETS-LINDGREN	HI-6005	00052473	0.1MHz ~ 5GHz	Oct. 01, 2013	RS

Note: Calibration Interval of instruments listed above is one year.



7 TEST LOCATION

SHIJR	ADD : 6Fl., No. 106, Sec. 1, Shintai 5th Rd., Shijr City, Taipei 221, Taiwan, R.O.C. TEL : 886-2-2696-2468 FAX : 886-2-2696-2255
HWA YA	ADD : No. 52, Hwa Ya 1st Rd., Hwa Ya Technology Park, Kwei-Shan Hsiang, Tao Yuan Hsien, Taiwan, R.O.C TEL : 886-3-327-3456 FAX : 886-3-327-0973
LINKOU	ADD : No. 30-2, Dingfu Vil., Linkou Dist., New Taipei City 244, Taiwan, R.O.C. TEL : 886-2-2601-1640 FAX : 886-2-2601-1695
DUNGHU	ADD : No. 3, Lane 238, Kangle St., Neihu Chiu, Taipei 114, Taiwan, R.O.C. TEL : 886-2-2631-4739 FAX : 886-2-2631-9740
JUNGHE	ADD : 7Fl., No. 758, Jungjeng Rd., Junghe City, Taipei 235, Taiwan, R.O.C. TEL : 886-2-8227-2020 FAX : 886-2-8227-2626
NEIHU	ADD : 4Fl., No. 339, Hsin Hu 2 nd Rd., Taipei 114, Taiwan, R.O.C. TEL : 886-2-2794-8886 FAX : 886-2-2794-9777
JHUBEI	ADD : No.8, Lane 724, Bo-ai St., Jhubei City, HsinChu County 302, Taiwan, R.O.C. TEL : 886-3-656-9065 FAX : 886-3-656-9085



Appendix A. Test Photos

1 Photographs of Radiated Emission Test Configuration

Below 1GHz

FRONT VIEW

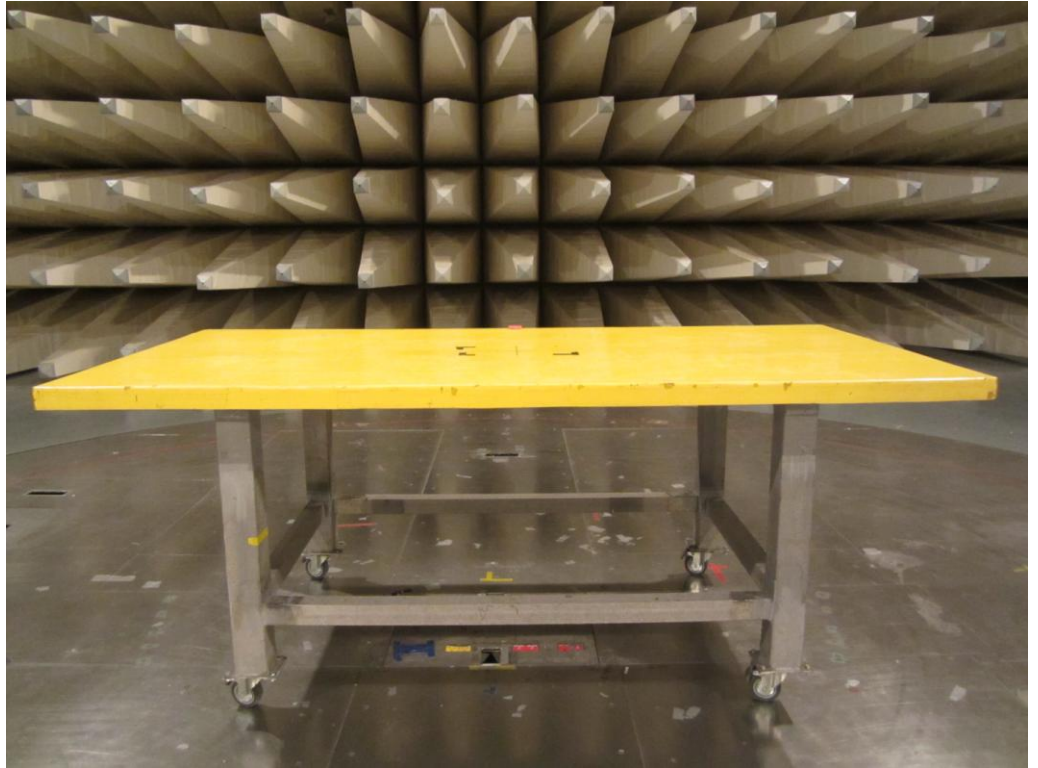

REAR VIEW

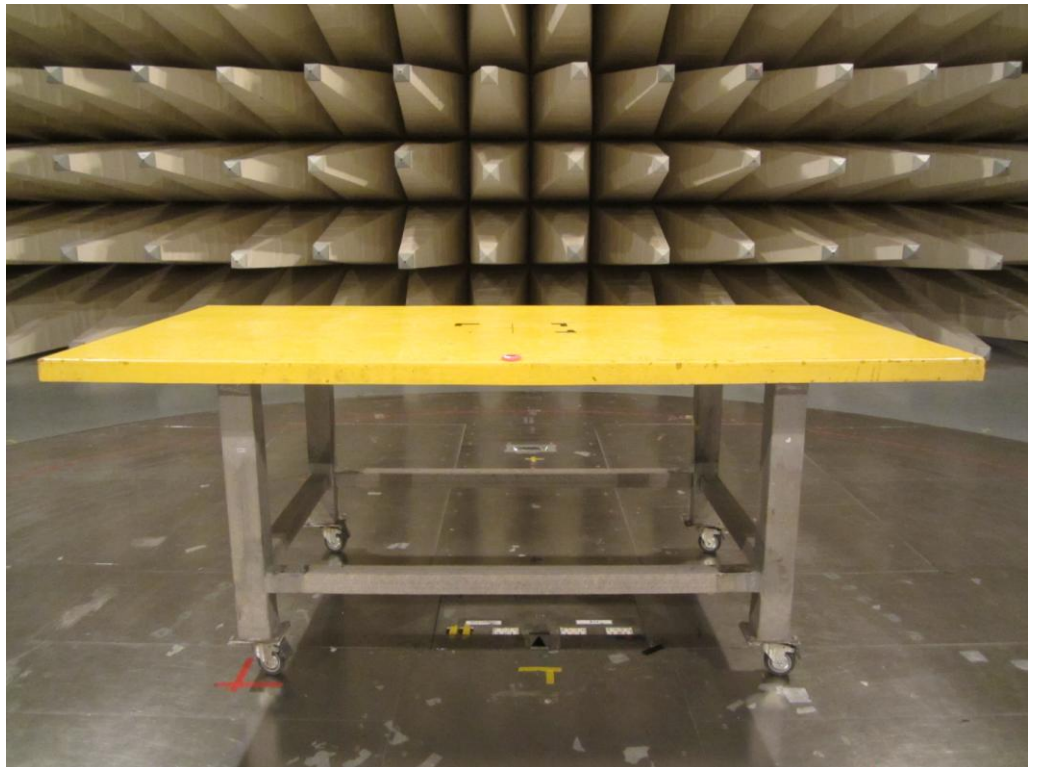

From 1GHz to 6GHz

FRONT VIEW

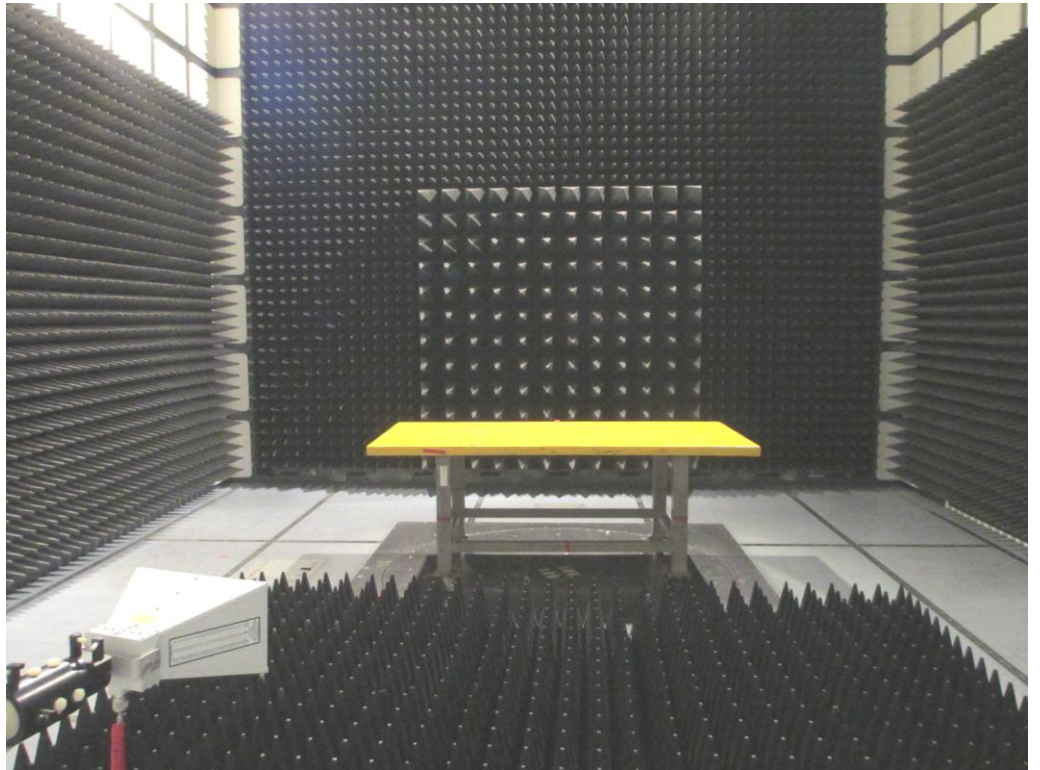

REAR VIEW

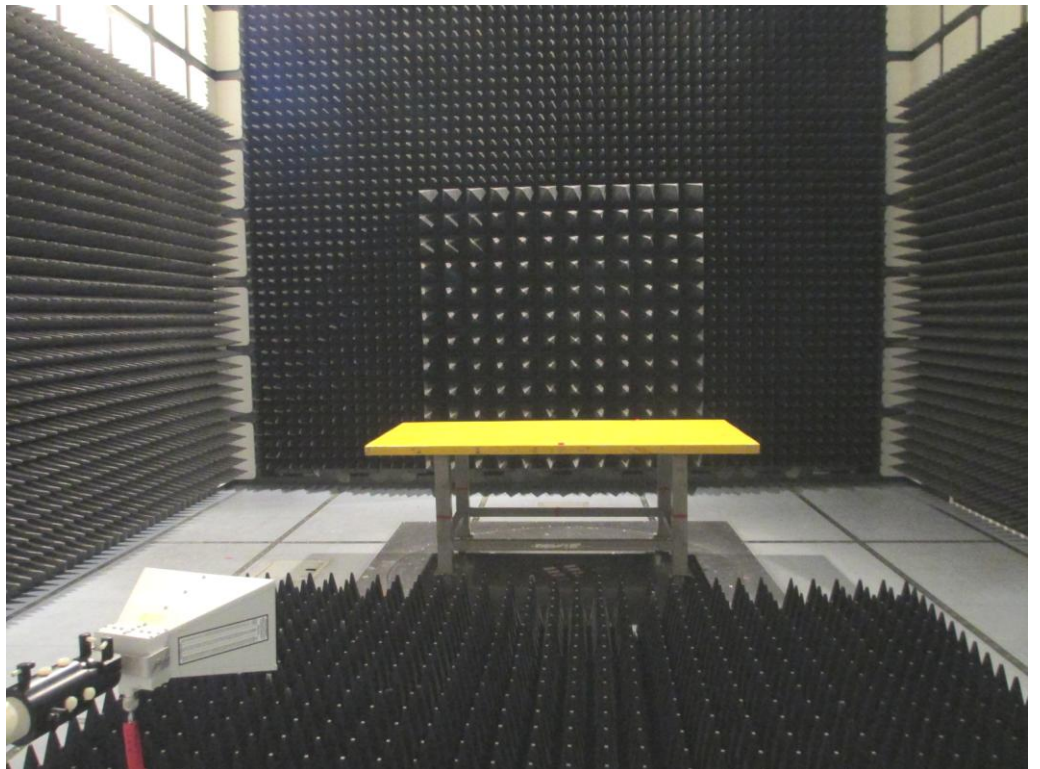

2 Photographs of ESD Immunity Test Configuration

FRONT VIEW



REAR VIEW



Test Points

FRONT VIEW



REAR VIEW



TOP VIEW



3 Photographs of RS Immunity Test Configuration

FRONT VIEW



REAR VIEW

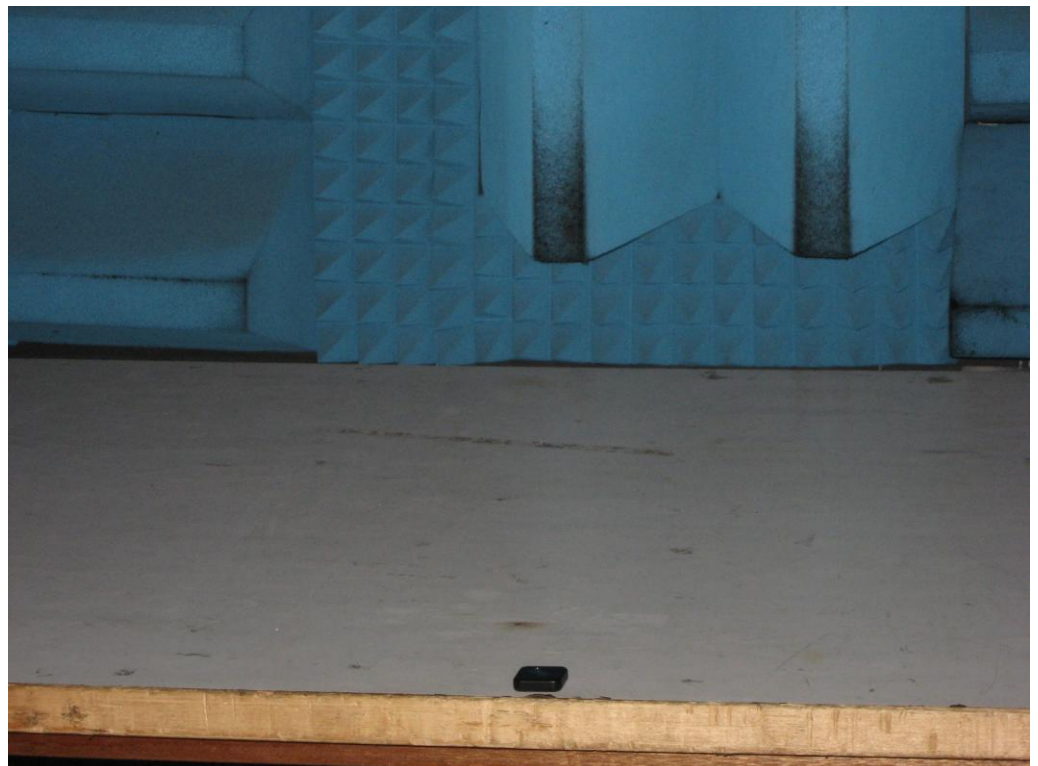

APPENDIX B. Photographs of EUT

